



BUSINESS IS PERSONAL

Your desk phone can drive your digital transformation

ALE | Where Everything Connects

OpenTouch® Suite for MLE

8078s Premium DeskPhone
8068s Premium DeskPhone
8058s Premium DeskPhone
8028s Premium DeskPhone
8018 DeskPhone

User Manual

8AL90339ENABed01-1737

Introduction

Thank you for choosing an ALE International phone.



This model offers enhanced ergonomical features for more effective communication.

Your phone can be used in any business environment, from on-premise PBX, to cloud deployment on multiple platforms, such as Alcatel-Lucent Enterprise servers or third-party SIP telephony platforms.

This document describes the services offered by the following sets connected to an OmniPCX Enterprise system:

- Alcatel-Lucent 8078s Bluetooth® Premium DeskPhone (8078s BT).
- Alcatel-Lucent 8078s Premium DeskPhone (8078s).
- Alcatel-Lucent 8068s Bluetooth® Premium DeskPhone (8068s BT).
- Alcatel-Lucent 8068s Premium DeskPhone (8068s).
- Alcatel-Lucent 8058s Premium DeskPhone (8058s).
- Alcatel-Lucent 8028s Premium DeskPhone (8028s).
- Alcatel-Lucent 8018 DeskPhone (8018).

The label and icons displayed depend on the type and the skin of the set. The label is not displayed if the corresponding feature is not configured on your telephone system. Depending on the size of the display, some labels may be truncated. *All labels are displayed in color and are italicized.* This icon describes a succession of actions or labels you have to do or select: **➤**.

This icon describes the consequence of an action: **➤➤**.

Some features depend on the type of the set.

	8078s BT	8078s	8068s BT	8068s	8058s	8028s	8018
IP Phone	●	●	●	●	●	●	●
Color screen	●	●	●	●	●		
Monochrome screen						●	●
Busy light logo on back shell	●	●	●	●	●		
Theme (skin)	●	●	●	●	●		
Bluetooth® handset	●		●				
Bluetooth® Smart Ready	●	●	●	●			
Two-port Gigabit Ethernet switch with Power Over Ethernet support	●	●	●	●	●	●	●
Premium Add-on 10 keys modules			●	●	●	●	
Premium Smart display 14 keys module	●	●	●	●	●	●	
Premium add-on 40-key modules	●	●	●	●	●	●	
Audio services (hands-free, handset and headset)	●	●	●	●	●	●	●
Adjusting the contrast of the display						●	●
Ambient light sensor	●	●	●	●	●		
Agent set / Supervisor station	●	●	●	●			
Remote Worker	●	●	●	●	●	●	●
SIP mode or SIP survivability			●	●	●	●	●

The labels and icons presented in this document are not contractually binding and may be modified without prior warning.

1	GETTING TO KNOW YOUR TELEPHONE	8
1.1	8078S BLUETOOTH/ 8078S PREMIUM DESKPHONE	8
1.2	8068S BLUETOOTH/ 8068S PREMIUM DESKPHONE	10
1.3	8058S PREMIUM DESKPHONE	12
1.4	8028S PREMIUM DESKPHONE	14
1.5	8018 DESKPHONE	16
1.6	WELCOME SCREENS	18
1.7	USER LOCAL MENU	19
1.8	STATUS ICONS/ CALL ICONS	20
1.9	PERMANENT FEATURES KEYS	20
1.10	KEYBOARD	21
1.11	DESCRIPTION OF THE CONNECTORS	23
1.12	ADD-ON MODULE	24
1.13	ALE WIDEBAND BLUETOOTH® HANDSET	27
1.14	ALE BLUETOOTH® HANDSET	29
1.15	INSTALL A COMFORT WIRED HANDSET	31
2	USING YOUR TELEPHONE	32
2.1	CONSULTING THE CALL LOG	32
2.2	MAKING A CALL	32
2.3	RECEIVING A CALL	33
2.4	SWITCHING BETWEEN AUDIO MODES	33
2.5	ACTIVATING THE LOUDSPEAKER DURING A CONVERSATION (HANDSET LIFTED) LOUDSPEAKER.	34
2.6	MAKE CALLS BY NAME (COMPANY DIRECTORY)	34
2.7	MAKE CALLS VIA YOUR PROGRAMMED CALL KEYS	34
2.8	REDIALING	34
2.9	CALLBACK REQUESTS	35
2.10	CALL BACK AN UNANSWERED CALL	35
2.11	REQUESTING AUTOMATIC CALLBACK IF INTERNAL NUMBER IS BUSY	36
2.12	RECEIVING INTERPHONY CALLS	36
2.13	SENDING DTMF SIGNALS	36
2.14	MUTE, SO THAT YOUR CONTACT CANNOT HEAR YOU	37
3	DURING A CONVERSATION	38
3.1	MAKING A SECOND CALL DURING A CONVERSATION	38
3.2	ANSWERING A SECOND CALL DURING A CONVERSATION	38
3.3	SWITCHING BETWEEN CALLS (BROKER CALL)	39
3.4	TRANSFERRING A CALL	39
3.5	THREE-WAY CONFERENCE WITH INTERNAL AND/OR EXTERNAL CONTACTS (CONFERENCE)	39
3.6	TALK SIMULTANEOUSLY TO MORE THAN 2 CONTACTS	39
3.7	PLACING A CALL ON HOLD (HOLD)	40
3.8	PLACING AN OUTSIDE CALL ON HOLD (PARKING)	40
3.9	INTRUSION INTO AN INTERNAL CONVERSATION (BARGE-IN)	41
3.10	SIGNAL MALICIOUS CALLS	41

4	SHARING	42
4.1	ANSWERING THE GENERAL BELL	42
4.2	MANAGER/ASSISTANT FILTERING	42
4.3	CALL PICK-UP	42
4.4	HUNTING GROUPS	43
4.5	CALLING AN INTERNAL CONTACT ON HIS/HER PAGER	43
4.6	ANSWERING A CALL ON YOUR PAGER	43
4.7	CALLING A CONTACT ON HIS/HER LOUDSPEAKER	43
4.8	SENDING A WRITTEN MESSAGE TO AN INTERNAL CONTACT	44
4.9	CONSULTING WRITTEN MESSAGES	44
4.10	SEND A VOICE MESSAGE COPY	45
4.11	SENDING A RECORDED MESSAGE TO A NUMBER OR A DISTRIBUTION LIST	45
4.12	BROADCASTING A MESSAGE ON THE LOUDSPEAKERS OF A STATION GROUP	45
5	KEEP IN TOUCH	46
5.1	FORWARDING CALLS TO ANOTHER NUMBER (IMMEDIATE FORWARD)	46
5.2	FORWARDING CALLS TO YOUR VOICE MESSAGE SERVICE	46
5.3	FORWARDING CALLS IF YOU DO NOT ANSWER OR IF YOU ARE BUSY	46
5.4	WHEN YOU RETURN, CONSULT RECORDED MESSAGES	47
5.5	FORWARDING CALLS TO YOUR PAGER	47
5.6	FORWARDING YOUR CALLS FROM THE RECEIVING TERMINAL ('FOLLOW ME')	47
5.7	APPLYING A SELECTIVE FORWARD	48
5.8	DO NOT DISTURB	48
5.9	CANCELLING ALL FORWARDS	48
5.10	LEAVING A RECORDED MESSAGE FOR INTERNAL CALLERS	48
6	MANAGING YOUR CHARGES	50
6.1	CHARGING YOUR CALLS DIRECTLY TO BUSINESS ACCOUNTS	50
6.2	FINDING OUT THE COST OF AN OUTSIDE CALL MADE FOR AN INTERNAL USER FROM YOUR TERMINAL	50
7	PROGRAMMING YOUR TELEPHONE	51
7.1	INITIALIZING YOUR VOICE MAILBOX	51
7.2	CUSTOMIZING YOUR VOICE GREETING	51
7.3	MODIFY THE PASSWORD FOR YOUR PHONE SET	51
7.4	MODIFY THE PASSWORD FOR YOUR VOICE MAILBOX	52
7.5	ADJUSTING THE AUDIO FUNCTIONS	52
7.6	ADJUSTING THE BRIGHTNESS OF THE DESKPHONE (8078s, 8068s, 8058s, 8028s PREMIUM DESKPHONE)	53
7.7	ADJUSTING THE CONTRAST OF THE DISPLAY (8028s, 8018)	54
7.8	SELECTING THE WELCOME PAGE	54
7.9	SELECTING LANGUAGE	54
7.10	PROGRAMMING KEYS FOR CALL NUMBERS AND FUNCTIONS (PERSO PAGE/F1 AND F2 KEYS/ADD-ON KEYS)	54
7.11	MODIFY A PROGRAMMED KEY	55
7.12	DELETE A PROGRAMMED KEY	55
7.13	PROGRAMMING AN APPOINTMENT REMINDER	56
7.14	IDENTIFY THE TERMINAL YOU ARE ON	56
7.15	LOCK / UNLOCK YOUR TELEPHONE	56
7.16	INSTALL A JACK ACCESSORY (HEADSET, HANDS-FREE, LOUDSPEAKER) (8078s, 8068s, 8058s, 8028s PREMIUM DESKPHONE)	56
7.17	INSTALL A USB ACCESSORY (HEADSET, HANDSFREE, LOUDSPEAKER)	57
7.18	MANAGE CONNECTED DEVICES	57

7.19 CALL THE ASSOCIATED SET	58
7.20 FORWARD YOUR CALLS TO THE ASSOCIATED NUMBER	58
7.21 MODIFY THE ASSOCIATED NUMBER	58
7.22 THE TANDEM CONFIGURATION	58
7.23 CREATE, MODIFY OR CONSULT YOUR INTERPHONY LIST (MAX. 10 NUMBERS)	58
7.24 INSTALLING AND USING AN ALE BLUETOOTH® WIRELESS HANDSET	59
7.25 INSTALLING A BLUETOOTH® WIRELESS TECHNOLOGY HEADSET (PAIRING)	59
7.26 USING A BLUETOOTH® WIRELESS TECHNOLOGY HEADSET	59
7.27 DISPLAY ALL PAIRED BLUETOOTH® DEVICES	60
7.28 REMOVING A BLUETOOTH® ACCESSORY (HEADSET, HANDSET, ETC.)	60
7.29 PAIR YOUR PHONE AS A BLUETOOTH® DEVICE	60
7.30 CONFIGURE YOUR PHONE FOR TELEWORKING	61
7.31 CONTACTING YOUR ADMINISTRATOR (TECHNICAL SUPPORT)	64
7.32 PHONE AUTO TEST	65
8 'MEET ME' CONFERENCE	66
8.1 INITIATE A 'MEET ME' CONFERENCE	66
8.2 JOIN A 'MEET ME' CONFERENCE	66
9 ACD: AGENT SET/ SUPERVISOR STATION	67
9.1 AGENT SET	67
9.2 OPEN AN AGENT SESSION (LOGON) – AGENT SET	67
9.3 ACD APPLICATION WELCOME SCREEN – AGENT SET	67
9.4 CLOSE AN AGENT SESSION (LOGOFF)	68
9.5 SUPERVISOR STATION	68
9.6 OPEN A SUPERVISOR SESSION (LOGON)	68
9.7 PROCESSING GROUP- SUPERVISOR ENTRY/WITHDRAWAL	68
9.8 SUPERVISION OR ACCEPTANCE OF AN ASSISTANCE REQUEST	69
9.9 CLOSE A SUPERVISOR SESSION	69
10 USE THE TELEPHONE IN SIP SURVIVABILITY ('SAFE' MODE)	70
10.1 MAKING A CALL	70
10.2 MAKE A CALL USING THE PERSONAL PHONE BOOK	71
10.3 REDIALING THE LAST NUMBER DIALED	71
10.4 RECEIVING A CALL	71
10.5 MAKING A SECOND CALL DURING A CONVERSATION	71
10.6 ANSWERING A SECOND CALL DURING A CONVERSATION	72
10.7 PLACING A CALL ON HOLD (HOLD)	72
10.8 SWITCHING BETWEEN CALLS (BROKER CALL)	73
10.9 TRANSFERRING A CALL	73
10.10 THREE-WAY CONFERENCE WITH INTERNAL AND/OR EXTERNAL CONTACTS (CONFERENCE)	73
10.11 MUTE, SO THAT YOUR CONTACT CANNOT HEAR YOU	73
10.12 ADJUST AUDIO VOLUME	74
10.13 FORWARDING CALLS TO ANOTHER NUMBER (IMMEDIATE FORWARD)	74
10.14 ADJUSTING THE AUDIO FUNCTIONS	74
10.15 SELECTING LANGUAGE	75
10.16 SENDING DTMF SIGNALS	75

11 ACCESSORIES	76
11.1 LIST OF ACCESSORIES	76
11.2 8115/8125 AUDIOFFICE	77
11.3 EXTERNAL RINGING INTERFACE MODULE (MWS 3GV28050AA)	82
11.4 WALL MOUNTING KIT	84
11.5 CONNECT A 3 POLE JACK HEADSET	86
12 TECHNICAL SPECIFICATIONS	87
13 ORDERING INFORMATION	90
14 GUARANTEE AND CLAUSES	91
14.1 SAFETY INSTRUCTIONS	91
14.2 REGULATORY STATEMENTS	92

The information presented is subject to change without notice. ALE International assumes no responsibility for inaccuracies contained herein. Copyright© ALE International 2017.

1 Getting to know your telephone

1.1 8078s Bluetooth/ 8078s Premium DeskPhone

This phone is part of the IP phone range. With its 5-inch color touchscreen display, the 8078s Premium DeskPhone delivers a great user experience and great conversation convenience with an outstanding audio quality in either hands-free mode or using the comfort handset. Additionally, the 8078s Bluetooth® Premium DeskPhone improves your experience with its Bluetooth® handset or other Bluetooth® accessories. The 8078s Bluetooth® Premium DeskPhone is 'Bluetooth® Smart Ready'. You can personalize the phone by selecting a theme (skin). It is compatible with teleworking. Consequently, it is perfect for use at your office in your enterprise or at home (teleworking).

1.1.1 Phone description



- 1** LED
Flashing blue: incoming call.
Flashing orange: alarm.
- 2** Color touchscreen display with auto brightness adjustment which improves the user experience and achieves power savings (ambient light sensor).
- 3** Permanent feature keys: quick access to the phone's main features.
- 4** Bluetooth® wireless handset (8078s BT).
Wired handset.
- 5** 3.5 mm, 4 pole jack (TRRS standards: CTIA).
- 6** Magnetic alphabetic keyboard.
- 7** An adjustable and stable foot.
- 8** Loudspeaker.

1.1.2 Main screen

Date and time

Thu 09 Feb 2017 14:12

menu perso info > ↗

Line BlkDial

Line John

Line Clara

Line Pierre

Navigation softkeys and quick access to specific settings: [Home] [Back] [OK] [Bluetooth]

Forward icon: [Forward]

Softkeys: Menus and actions available depending on the selected page.

	Select a page by pressing the corresponding tab on the screen. The selected page is highlighted. Make your selection by pressing the label on the screen.
	Scroll a list (features, call log, contact, ...) by pressing the up and down arrow on the screen, or on the keyboard.
	Manage your call forwarding by pressing the forward icon. <ul style="list-style-type: none"> • Stationary arrow: No forwarding activated. • Blinking arrow: Forwarding activated.
	Use the 'OK' softkey to validate your choices and options while programming or configuring.
	Use the 'Back/Exit' icon to go back to the previous step.
	Use the 'Setting' icon for quick access to the user local menu.
	Use the 'Bluetooth®' icon to open Bluetooth® settings.

1.1.3 Call management screen



Incoming call icon, Call in progress, Call on hold, ...



Notification (popup) of incoming call

Soft keys: actions available depending on the call status (when presentation screen is not displayed)



- Each tab corresponds to a call, the status of which is symbolized by its icon (in progress, call on hold, arrival of new call). When a call is in progress, press on the corresponding tab to look at calls on hold or incoming calls.
- All features are accessible while the call is displayed on the screen. Use the Up and Down arrows to move up or down a page. These functions (transfer, conference, etc.) are directly related to the status of the call consulted. For example, the transfer function will not be available between a call in progress or on hold and an incoming call.
- Used to switch from the conversation screen to the welcome screen.

Calls can also be managed from the Perso page. While the call is in progress, press the Back/Exit key and display the Perso page. Calls in progress or waiting calls are displayed on the different line keys. It is then possible to converse with the contact of your choice by pressing the key associated to the contact.

1.1.4 Access to the user local menu

 or  (long press): Open the user local menu: *Audio, Display, Bluetooth®, Skin* (See: User local menu).

1.1.5 Change the theme (skin) of your phone

- The phone is in idle state.
-  or  (long press) *Skin*
- Select the desired new theme from the list.
- 

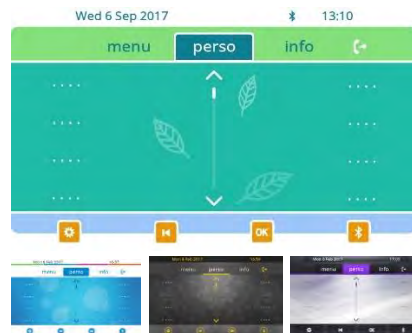

Changing the theme may take a few seconds.



A corporate theme can be installed by your administrator. In this case, you cannot change the theme. The ringtone settings can be integrated into a theme.

1.1.6 Busy light logo on back shell

The logo on back shell can be illuminated. The color changes when you are busy.

- The phone is in idle state.
-  or  (long press) *Display > Advanced > Busy light*
- Activate or deactivate the logo LED feature.
- 



1.1.7 Bluetooth Smart Ready



Your phone is 'Bluetooth® Smart Ready'. It can receive and share Bluetooth® signals from various Bluetooth® devices (Bluetooth® and Bluetooth® Smart or Low-energy devices). It is ready for future services available on the fly in a subsequent software upgrade. This feature can be deactivated by the administrator.

1.2 8068s Bluetooth/ 8068s Premium DeskPhone

This phone is part of the IP phone range. With its color display associated to 10 dedicated functions keys, and an intuitive navigation key, the 8068s Premium DeskPhone delivers a great user experience and great conversation convenience with an outstanding audio quality in either hands-free mode or using the comfort handset. Additionally, the 8068s Bluetooth® Premium DeskPhone improves your experience with its Bluetooth® handset or other Bluetooth® accessories. The 8068s Bluetooth® Premium DeskPhone is 'Bluetooth® Smart Ready'. You can personalize the phone by selecting a theme (skin). It is compatible with teleworking. Consequently, it is perfect for use at your office in your enterprise or at home (teleworking).

1.2.1 Phone description



- 1** LED
Flashing blue: incoming call.
Flashing orange: alarm.
Color display with auto brightness adjustment which enhances user experience and saves power (ambient light sensor).
- 2** 10 dedicated functions keys.
- 3** Navigation.
- 4** Permanent feature keys: quick access to the phone's main features.
- 5** Bluetooth® wireless handset (8068s BT).
Wired handset.
- 6** 3.5 mm, 4 pole jack (TRRS standards: CTIA).
- 7** Magnetic alphabetic keyboard.
- 8** An adjustable and stable foot.
- 9** Loudspeaker.

1.2.2 Main screen

Date and time

Display the page by selecting the corresponding tab.

Forward icon.

Softkeys: Menus and actions available depending on the selected page.

- OK key:** Use this key to validate your choices and options while programming or configuring.
- Left-right navigator:** In idle state, use this key to move from one page to another. In conversation, use this key to move between tabs of current calls (call in progress, calls on hold, incoming call). In the text edition, use this key to navigate into the text box.
- Up-down navigator:** Used to scroll through the content of a page.
- Back/Exit key:** Use this key to go back to the previous step. Use this key to go back to the homepage (long press).
- Manage your call forwarding by pressing the key associated with the forward icon.
 - Stationary arrow: No forwarding activated.
 - Blinking arrow: Forwarding activated.

1.2.3 Call management screen

Incoming call icon, Call in progress, Call on hold, ...

Notification (popup) of incoming call

Soft keys: actions available depending on the call status (when presentation screen is not displayed)

- Each tab corresponds to a call, the status of which is symbolized by its icon (in progress, call on hold, arrival of new call). When a call is in progress, use the left-right navigator to look at calls on hold or incoming calls.
- All features are accessible while the call is displayed on the screen. Use the Up and Down arrows to move up or down a page. These functions (transfer, conference, etc.) are directly related to the status of the call consulted. For example, the transfer function will not be available between a call in progress or on hold and an incoming call.
- Used to switch from the conversation screen to the welcome screen
- Press the key in front of the label to select the corresponding feature.

Calls can also be managed from the Perso page.

While the call is in progress, press the Back/Exit key and display the Perso page. Calls in progress or waiting calls are displayed on the different line keys. It is then possible to converse with the contact of your choice by pressing the key associated to the contact.

1.2.4 Access to the user local menu

(long press) › Open the user local menu: *Audio, Display, Bluetooth®, Skin* (See: User local menu).

1.2.5 Change the theme (skin) of your phone

- The phone is in idle state.
 - (long press) › *Skin*
 - Select the desired new theme from the list.
 -
- Changing the theme may take a few seconds.

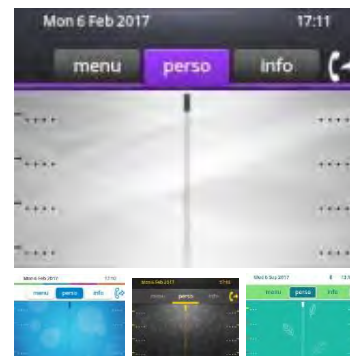

A corporate theme can be installed by your administrator. In this case, you cannot change the theme. The ringtone settings can be integrated into a theme.

1.2.6 Busy light logo on back shell

The logo on back shell can be illuminated. The color changes when you are busy.

- The phone is in idle state.
- (long press) › *Display* › *Advanced* › *Busy light*
- Activate or deactivate the logo LED feature.
-



1.2.7 Bluetooth Smart Ready



You phone is 'Bluetooth® Smart Ready'. It can receive and share Bluetooth® signals from various Bluetooth® devices (Bluetooth® and Bluetooth® Smart or Low-energy devices). It is ready for future services available on the fly in a subsequent software upgrade. This feature can be deactivated by the administrator.

1.3 8058s Premium DeskPhone

This phone is part of the IP phone range. In addition to a color display associated to 6 dedicated function keys and an intuitive navigation key, the 8058s Premium DeskPhone provides 4 programmable softkeys as a smart add-on module, for a quick access to your favorite contacts or features. It provides high audio fidelity for telephone calls either in hands-free mode or using the comfort handset. You can personalize the phone by selecting a theme (skin). It is compatible with teleworking. Consequently, it is perfect for use at your office in your enterprise or at home (teleworking).







1.3.1 Phone description



- 1** LED
Flashing blue: incoming call.
Flashing orange: alarm.
- 2** Color display with auto brightness adjustment which enhances user experience and saves power (ambient light sensor).
- 3** 6 dedicated functions keys.
- 4** 4 programmable softkeys with LED.
- 5** Navigation.
- 6** Permanent feature keys: quick access to the phone's main features.
- 7** Wired handset.
- 8** 3.5 mm, 4 pole jack (TRRS standards: CTIA).
- 9** Magnetic alphabetic keyboard.
- 10** An adjustable and stable foot.
- 11** Loudspeaker.

1.3.2 Main screen



-  **OK key:** Use this key to validate your choices and options while programming or configuring.
-  **Left-right navigator:** In idle state, use this key to move from one page to another. In conversation, use this key to move between tabs of current calls (call in progress, calls on hold, incoming call). In the text edition, use this key to navigate into the text box.
-  **Up-down navigator:** Used to scroll through the content of a page.
-  **Back/Exit key:** Use this key to go back to the previous step. Use this key to go back to the homepage (long press).
-  Manage your call forwarding by pressing the key associated with the forward icon.
 -  Stationary arrow: No forwarding activated.
 -  Blinking arrow: Forwarding activated.

1.3.3 Call management screen



- Each tab corresponds to a call, the status of which is symbolized by its icon (in progress, call on hold, arrival of new call). When a call is in progress, use the left-right navigator to look at calls on hold or incoming calls.
- All features are accessible while the call is displayed on the screen. Use the Up and Down arrows to move up or down a page. These functions (transfer, conference, etc.) are directly related to the status of the call consulted. For example, the transfer function will not be available between a call in progress or on hold and an incoming call.
- Used to switch from the conversation screen to the welcome screen.
- Press the key in front of the label to select the corresponding feature.

Calls can also be managed from the Perso page.

While the call is in progress, press the Back/Exit key and display the Perso page. Calls in progress or waiting calls are displayed on the different line keys. It is then possible to converse with the contact of your choice by pressing the key associated to the contact.

1.3.4 Access to the user local menu

(long press) › Open the user local menu: *Audio, Display, Skin* (See: User local menu).

1.3.5 Change the theme (skin) of your phone

- The phone is in idle state.
 - (long press) › *Skin*
 - Select the desired new theme from the list.
 -
- Changing the theme may take a few seconds.

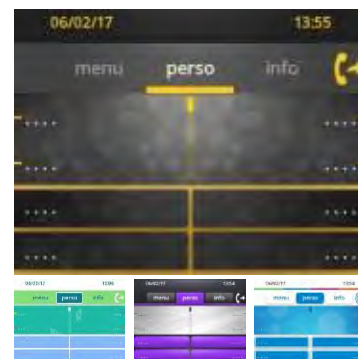

A corporate theme can be installed by your administrator. In this case, you cannot change the theme. The ringtone settings can be integrated into a theme.

1.3.6 Busy light logo on back shell

The logo on back shell can be illuminated. The color changes when you are busy.

- The phone is in idle state.
- (long press) › *Display* › *Advanced* › *Busy light*
- Activate or deactivate the logo LED feature.
-



1.4 8028s Premium DeskPhone

This phone is part of the IP phone range. In addition to a clear monochrome display associated to 6 dedicated function keys and an intuitive navigation key, the 8028s Premium DeskPhone provides 4 programmable keys as a smart add-on module, for a quick access to your favorite contacts or features. It provides high audio fidelity for telephone calls either in hands-free mode or using the comfort handset. It is compatible with teleworking. Consequently, it is perfect for use at your office in your enterprise or at home (teleworking).







1.4.1 Phone description

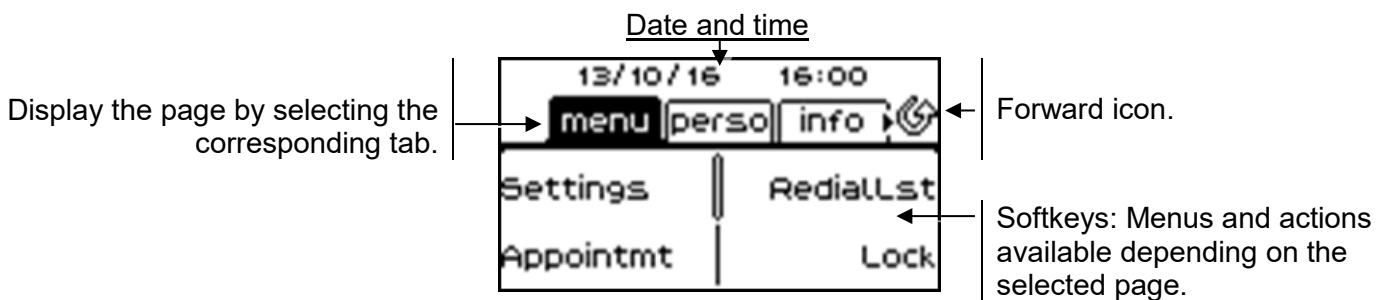

- 1** LED
Flashing blue: incoming call.
Flashing orange: alarm.
- 2** Monochrome backlit screen.
- 3** 6 dedicated functions keys.
- 4** 4 programmable keys with Led and paper label.
- 5** Navigation.
- 6** Permanent feature keys: quick access to the phone's main features.
- 7** Wired handset.
- 8** 3.5 mm, 4 pole jack (TRRS standards: CTIA).
- 9** Magnetic alphabetic keyboard.
- 10** An adjustable and stable foot.
- 11** Loudspeaker.

1.4.2 Main screen





-  **OK key:** Use this key to validate your choices and options while programming or configuring.
-  **Left-right navigator:** In idle state, use this key to move from one page to another. In conversation, use this key to move between tabs of current calls (call in progress, calls on hold, incoming call). In the text edition, use this key to navigate into the text box.
-  **Up-down navigator:** Used to scroll through the content of a page.
-  **Back/Exit key:** Use this key to go back to the previous step. Use this key to go back to the homepage (long press).
-  Manage your call forwarding by pressing the key associated with the forward icon.
 -  Stationary white icon: No forwarding activated.
 -  Blinking arrow: Forwarding activated.

1.4.3 Call management screen



- 

Each tab corresponds to a call, the status of which is symbolized by its icon (in progress, call on hold, arrival of new call). When a call is in progress, use the left-right navigator to look at calls on hold or incoming calls.
- 

All features are accessible while the call is displayed on the screen. Use the Up and Down arrows to move up or down a page. These functions (transfer, conference, etc.) are directly related to the status of the call consulted. For example, the transfer function will not be available between a call in progress or on hold and an incoming call.
- 

Used to switch from the conversation screen to the welcome screen.
- 

Press the key in front of the label to select the corresponding feature.

1.4.4 Access to the user local menu

 (long press) > Open the user local menu: *Audio, Display* (See:User local menu).

1.4.5 Changing or updating the paper label

Removing the paper label

- Lift the protective cover at the notch (1).
- Remove the paper label in the same way (2).
- Update or replace the paper label.

Inserting the phone label

- Position the phone label, left side first, making sure it is placed correctly behind the notches (a,b,c,d).
- Put the protective cover back in the same way.

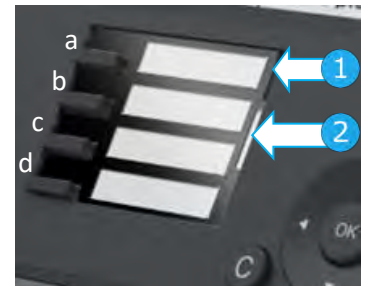

The application 'LabelSet' is available to help you to print the paper labels. Please contact your business partner for more information.

1.5 8018 DeskPhone

This phone is part of the IP phone range. In addition to a clear monochrome display associated to 6 dedicated function keys and an intuitive navigation key, the 8018 DeskPhone provides 4 programmable keys as a smart add-on module, for a quick access to your favorite contacts or features. It provides high audio fidelity for telephone calls either in hands-free mode or using the comfort handset. It is compatible with teleworking. Consequently, it is perfect for use at your office in your enterprise or at home (teleworking).



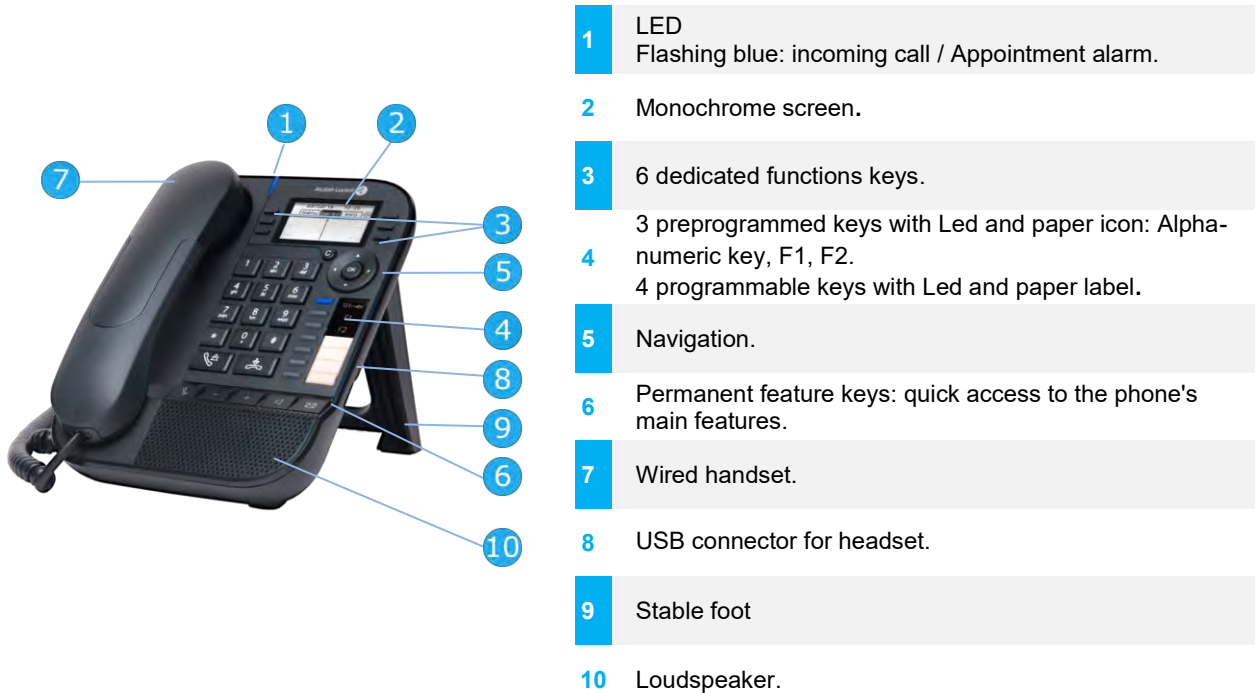



1.5.1 Phone description

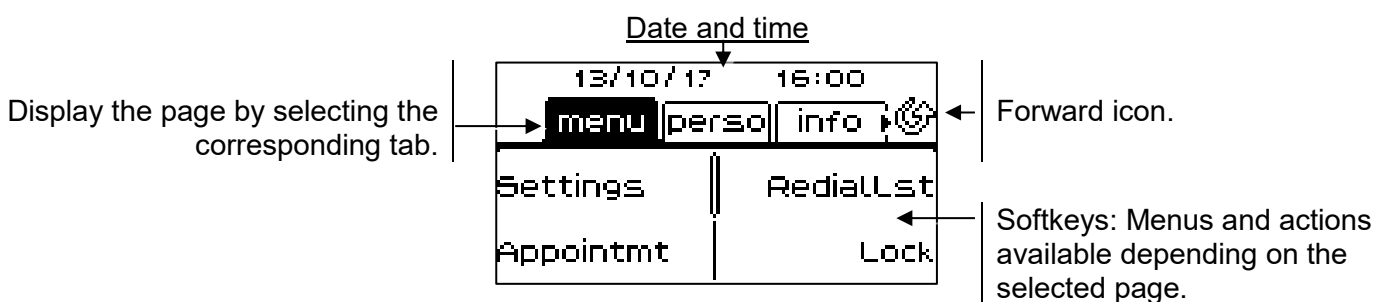

Your phone has 4 programmable keys with led and paper label. These keys are use to program a direct call. You can use the paper to describe the key.





1.5.2 Main screen



-  **OK key:** Use this key to validate your choices and options while programming or configuring.
-  **Left-right navigator:** In idle state, use this key to move from one page to another. In conversation, use this key to move between tabs of current calls (call in progress, calls on hold, incoming call). In the text edition, use this key to navigate into the text box.
-  **Up-down navigator:** Used to scroll through the content of a page.
-  **Back/Exit key:** Use this key to go back to the previous step. Use this key to go back to the homepage (long press). Use this key to delete one number or character at a time.
-  Manage your call forwarding by pressing the key associated with the forward icon.
 -  Stationary white icon: No forwarding activated.
 -  Blinking arrow: Forwarding activated.

1.5.3 Call management screen



-  Each tab corresponds to a call, the status of which is symbolized by its icon (in progress, call on hold, arrival of new call). When a call is in progress, use the left-right navigator to look at calls on hold or incoming calls.
-  All features are accessible while the call is displayed on the screen. Use the Up and Down arrows to move up or down a page. These functions (transfer, conference, etc.) are directly related to the status of the call consulted. For example, the transfer function will not be available between a call in progress or on hold and an incoming call.
-  Used to switch from a telephone screen to an application screen. For example, it can be used while a call is in progress to search a number, program an appointment reminder, etc
-  Press the key in front of the label to select the corresponding feature.

Calls can also be managed from the Perso page.

While the call is in progress, press the Back/Exit key and display the Perso page. Calls in progress or waiting calls are displayed on the different line keys. It is then possible to converse with the contact of your choice by pressing the key associated to the contact.

1.5.4 Changing or updating the paper label

Removing the paper label

- Lift the protective cover at the notch and slide it up to take it out of its housing.
- Remove the paper label in the same way.
- Update or replace the paper label.

Inserting the phone label

- Insert the paper label from the top end, making sure it is placed correctly behind the notches.
- Put the protective cover back in the same way.





The application 'LabelSet' is available to help you to print the paper labels. Please contact your business partner for more information.

1.5.5 Function keys and programmable keys



The 8018 DeskPhone uses 3 preprogrammed keys to access some features. In this case, the icon of the feature is printed on the paper. Use the feature by pressing the corresponding key. When activated, the LED corresponding to the key remains lit up. Press the corresponding key to deactivate it.

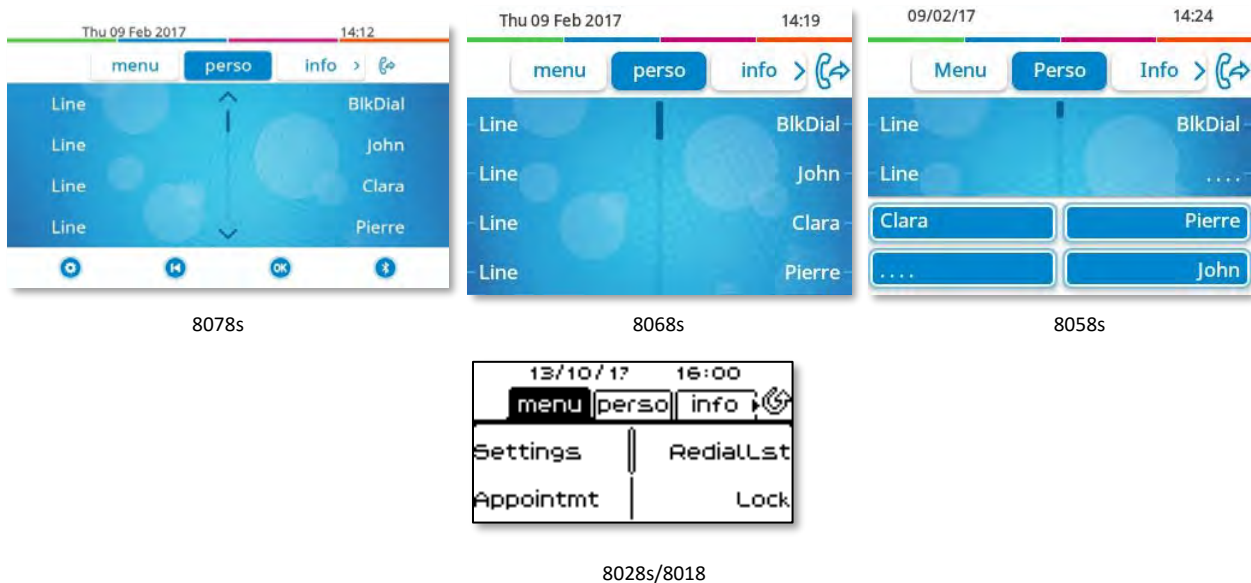

-  Alpha-numerical keypad
Use this key to switch between alphabetic keyboard and numeric keyboard.
-  Programmable keys (F1 and F2 keys). A service or a direct call can be associated to these keys.

1.6 Welcome screens



1.6.1 Homepage description



You can access all of your phone's features from these screens. The default display has three pages that you can access by pressing to the page tabs at the top of the screen. The selected page is highlighted. The default pages can be augmented with other applications (ACD for example) installed and/or configured on your system.

- Menu page *Menu*
Contains all features and applications accessible by pressing the label of the desired feature or application. From this page, it is possible to adjust the ringer volume, program the time of an appointment, lock the terminal, define the default page displayed, configure voice mail, and access telephone functions such as calling back one of the last numbers or intercepting calls.
- Perso page *Perso*
Contains call line keys (allowing supervision of calls) and programmable call keys.
- Info page *Info*
Contains information on the telephone and the status of its functions: name, telephone number, number of messages (including call log events, instant messages and voice messages), activation of transfer function, appointment reminder, etc.
-  /  Forward icon: Press the icon (touchscreen) or the key next to this icon to program or change the transfer function.
- Press the label (touchscreen) or press the key in front of the label to select the corresponding feature.
- The 8058s Premium DeskPhone provides 4 programmable softkeys. Press the key in front of the softkey to activate it (call a contact, forward to a number, ...).

Choose the page displayed by default on the telephone

- *Settings* > *Phone* > *Homepage*
- Select the default page (Menu, Perso, Info, Last page seen ...).
- **OK**

1.7 User local menu

 or  (long press): Open the user local menu.

The user local menu depends on the type of the set.

Audio

Use this menu to adjust the audio convenience according to your environment, the type of device connected and your audio preferences:

- **Jack config.**
Configure the type of the device connected to the audio jack (*Headset, Handsfree, Loudspeaker*).
- **Devices**
Select the preferred audio device (connected or integrated).
- **Hearing Aid**
Check this option if you are using a hearing aid.

Display

Use this menu to adjust the display of your set:

- **Auto-Brightness**
When this option is checked, the phone automatically adjusts the brightness of the display depending on the lighting conditions to improve user experience and achieve power savings (ambient light sensor).
- **Brightness**
Adjust the brightness of the display, the LEDs and the logo on back shell (optional).
- **Advanced > Low brightness**
When the phone is not in use, the brightness is dimmed. Adjust dimmed brightness.
- **Advanced > Busy light**
Activate/deactivate the light of the logo on back shell (optional). The logo on back shell can be illuminated. The color changes when you are busy.
- **Advanced > LED brightness auto**
When this option is checked, the phone automatically adjusts the LED brightness and the busy light logo on the back shell (if present) depending on the lighting conditions to improve user experience and achieve power savings (ambient light sensor).
- **Screensaver**
Set the delay before the brightness is dimmed when the phone is not in use.

Bluetooth®

Use this menu to configure the Bluetooth® device (optional):

- **Devices**
Display all paired Bluetooth® devices, remove a Bluetooth® accessory (headset, handset, etc.).
- **Search devices**
Install a Bluetooth® Wireless accessory (headset, handset, etc.).
- **Parameters**
Use your DeskPhone as a Bluetooth® audio accessory.

 The 8078s Premium DeskPhone has a specific icon (quick access) to manage Bluetooth® devices (add device, list of paired devices, remove device).

Skin





Change the theme (skin) of your phone (optional).

1.8 Status icons/ Call icons





Icons giving information about some specific configurations of the phone or about call status are displayed in the top bar of the screen.

Status icons

Depending on the size of the display, all status icons may not be displayed simultaneously. Which icons are displayed depends on their priority. The following icons are listed according to their priority, from the highest to the lowest.







	Silent mode.
	Telephone locked.
	Headset connected.
	Appointment programmed.
	Phone in Bluetooth® detectable mode.

Call icons

	Incoming call icon.
	Call in progress icon.
	Call holding icon.
	Your contact ended the conversation.

1.9 Permanent features keys

They are located just above the loudspeaker.

	<ul style="list-style-type: none"> Mute and interphony key. During a call, press this key to stop your contact from hearing you. When idle, press this key to switch the phone to interphony mode. When you receive a call, the phone hooks off automatically and you go straight into hands-free mode. When activated, this key is lit blue.
	<ul style="list-style-type: none"> Turn down the volume (ringing or call state). Decrease the brightness (idle state). Decrease the contrast (idle state).
	<ul style="list-style-type: none"> Turn up the volume (ringing or call state). Increase the brightness (idle state). Increase the contrast (idle state).
	<ul style="list-style-type: none"> Pressing this key answers an incoming call in hands-free mode (when activated, the key is lit blue). When a call is in progress, pressing this key switches from hands-free mode to headset or handset mode.
	<ul style="list-style-type: none"> Programmable keys (F1 and F2 keys). Lit when the function associated with the key is activated. A service or a direct call can be associated to these keys.
	<ul style="list-style-type: none"> Redial key: to access the 'Redial' feature. <ul style="list-style-type: none"> Last number redial (short press). Call back one of the last 8 numbers dialed (long press). <p>For the 8018 DeskPhone, the redial key is associated with the Off-hook key when the phone is in idle state: .</p>



- Quick access to user local menu (long press).
- Used to obtain information on functions of the 'menu' page and to program key of the 'perso' page (short press).
This key is not available on the 8018 DeskPhone, press and hold the alpha-numerical key for a short time.



- Messaging key to access the messaging portal (call log, voice messages and instant messages).
This key flashes blue when there is a new event such as a new voice message, a new instant message or a new event in the call log.

1.10 Keyboard

1.10.1 Magnetic alphabetic keyboard (8078s, 8068s, 8058s, 8028s Premium DeskPhone)

Your set is provided with a magnetic alphabetic keyboard. The keyboard depends on your country and languages. The magnetic keyboard is automatically fixed on the base of the set. It is connected to the corresponding connector behind the phone.



- Country variants:
 - AZERTY
 - QWERTZ
 - QWERTY (international)
 - QWERTY (nordic)

Use the keyboard to enter names while configuring the phone. Directly access the dial by name feature by entering the name of your contact on the keyboard.

Below is a list of the function keys that allow you to access all the symbols.



Cursor moving keys (left, right, up and down). Allows you to navigate edit boxes. Press the Alt key to access the left and up directions.



Caps lock: to write text in capital letters.



Alt key: to access specific and punctuation characters.



Enter key: to validate edited text.





Backspace key: to delete one character in an edit box.

1.10.2 Alpha-numeric keyboard (8018 DeskPhone)

Your phone is equipped with alphanumeric keyboard. You can switch between numeric keyboard to dial number, and alphabetic keyboard to enter text by pressing the corresponding preprogrammed key (usually the first preprogrammed key).

- **123<>abc** Switch the keyboard to the alphabetic mode by selecting the associated preprogrammed key. When activated, the LED corresponding to the key remains lit up.
- Enter alphabetic characters.
The number pad keys have letters that you can display by successive presses. The number is the last character in the series. Some special characters can be displayed by successively pressing the key:









*	% \$ / ~ & () [] = *
#	@ #
1 _ -	space - _ 1
0 +	+ . , ; : / \ ? ! 0

-  Use navigation keys to move the cursor into the text.
-  Press and hold the '*' key to switch from lowercase to uppercase mode, and vice versa.
-  use this key to delete the last entered character. The alphabetic mode remains activated.
- **123<>abc** Select the lit preprogrammed key to return to the numeric mode.

1.11 Description of the connectors

Various connections to allow phone extensions. The type of connectors you have depends on your phone.



		8078s	8068s	8058s	8028s	8018
1	 Universal Serial Bus (USB-c) connector	●	●	●		
2	 Add-on module/external ringer connector (SATA type).	●	●	●	●	
3	 Magnetic alphanumeric keyboard connector (RJ 9).	●	●	●	●	
4	 Universal Serial Bus (USB-a) connector for an audio equipment, a low smartphone charger or USB stick. For the 8018 DeskPhone, the USB connector is on the side of the deskphone.	●	●	●	●	●
5	 10/100/1000 Mbps Ethernet connectors to a PC (RJ45).	●	●	●	●	●
6	 10/100/1000 Mbps Ethernet connectors to the enterprise network (LAN - RJ45).	●	●	●	●	●
7	 DC power jack for an external power adaptor.	●	●	●	●	●
8	 Wired handset connector (RJ9).	●	●	●	●	●
	3.5 mm, 4 pole jack (TRRS standards: CTIA).	●	●	●	●	

CTIA standards

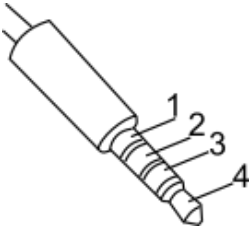
	1	Microphone
	2	Ground
	3	Audio (right)
	4	Audio (left)

1.12 Add-on module

Depending on your DeskPhone, phone capabilities can be extended with add-ons:



	8078s BT	8078s	8068s BT	8068s	8058s	8028s	8018
Premium Add-on 10 keys modules			●	●	●	●	
Premium Smart display 14 keys module	●	●	●	●	●	●	
Premium add-on 40-key modules	●	●	●	●	●	●	

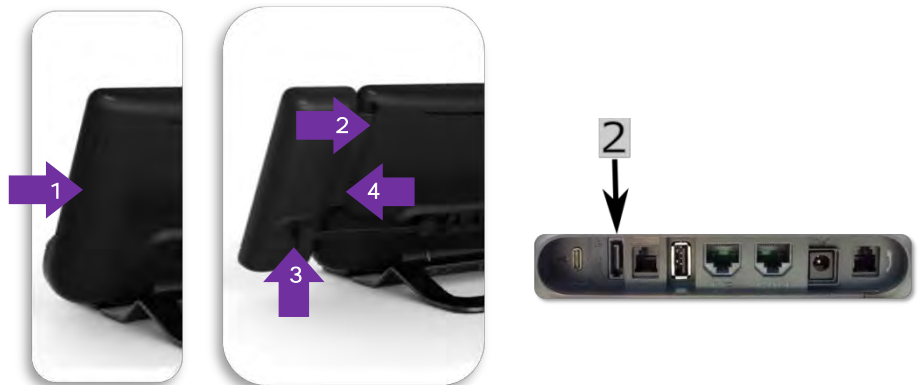

1.12.1 Install the add-on to the deskphone

- **Premium Add-on 10 keys**





- Remove the protection of the dedicated compartment behind the set.
- Insert the add-on correctly in the compartment.
- Plug the provided cord into the dedicated sockets behind your set and the add-on (2: ).
- Fix the add-on with the provided screw.
- Restart the deskphone (unplug and plug in the power jack if you are using an external power adapter or the Ethernet connector – LAN).
- **Premium Add-on 40 keys / Premium Smart Display 14 keys:**
 - Plug the provided cord into the dedicated socket behind your phone and behind the add-on ().
 - If desired, fix the foots (set and add-on) with the provided clip.
 - Restart the deskphone (unplug and plug in the power jack if you are using an external power adapter or the Ethernet connector – LAN).

Manage and use the add-on keys as a direct call key. See chapter: Programming your telephone.

1.12.2 Install more than one add-on module

It is possible to connect up to three add-on modules (Premium Smart Display 14 keys, Premium Add-on 40 keys). To attach another add-on, affix and connect the new add-on to the one that is already connected:

- o The first add-on is connected to the deskphone.
- o Plug the provided cord of the new add-on into the dedicated socket behind the connected add-on ().
- o Plug the other end of the cord into the dedicated socket behind the new add-on ().
- o Restart the deskphone (unplug and plug in the power jack if you are using an external power adapter or the Ethernet connector – LAN).

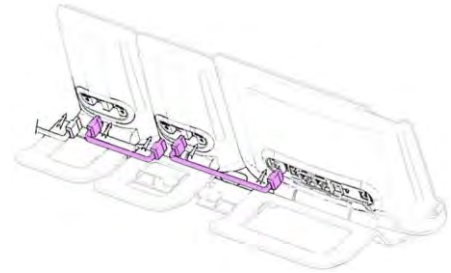

1.12.3 Attach the add-on with the clip

You can also order this clip separately for each of the two add-on modules. You can attach the base (set and add-on module) with the add-on clip provided with Premium Add-on module 40 keys and Premium Smart Add-on module 14 keys.

Premium Smart Add-on

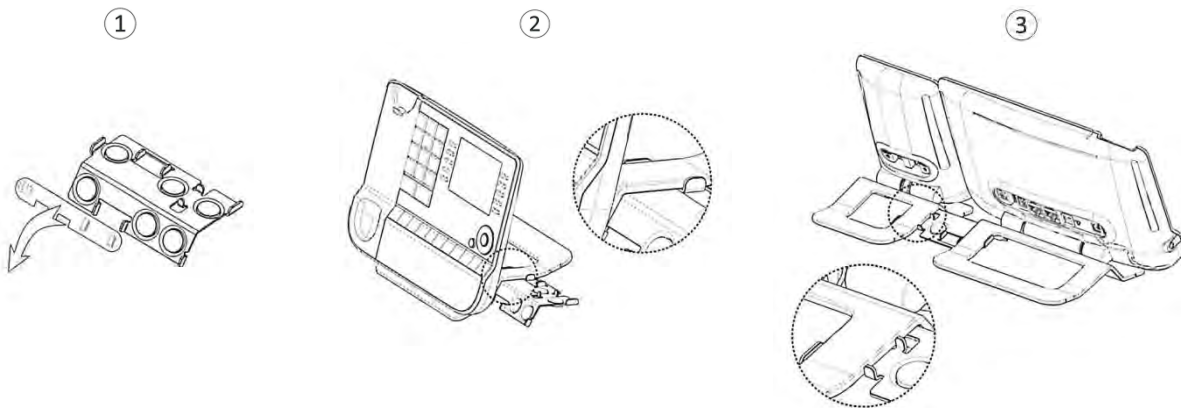

1 Remove the protection on the add-on clip

2 Place the clip in the correct position under the base of the phone, as shown in the image

3 Place the add-on onto the clip, as shown in the image

Premium Add-on 40

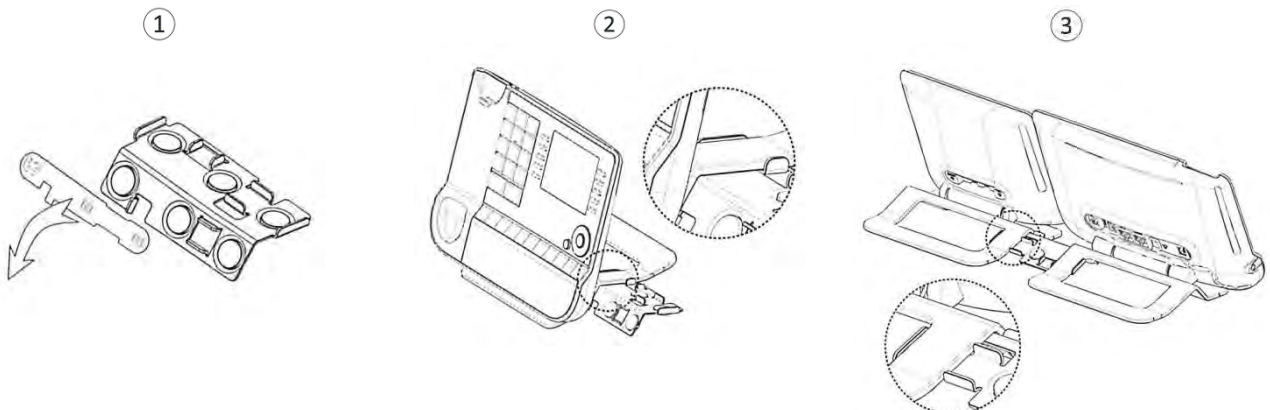

1 Remove the protection on the add-on clip

2 Place the clip in the correct position under the base of the phone, as shown in the image

3 Place the add-on onto the clip, as shown in the image

Use the same procedure to attach an add-on to another add-on.

You can attach one or more add-ons to your phone. To attach another add-on, affix and connect the new add-on to the one that is already connected.

1.12.4 Changing or updating the paper label

- **Premium Add-on 10 keys (with paper labels)**

- Remove the protective cover (1): Insert a thin object (or your fingernail) in the slot (a) to lift the protective cover. Carefully remove the cover at the first notch (b). The cover is held in place by small notches, take care not to break the plastic cover near the notches. Remove the cover from the other notches (c, d) by moving the cover gently from right to left (←→).
- Remove the paper label with a thin object.
- Replace the paper label and protective cover (2): The cover or the paper can only be placed in the right way. It has to cover all the paper area. If not, return it. Position the paper label, right side first, by inserting it under the plastic notches (a). Then, insert the other notches (b) by gently pressing the paper near each notch. Put the protective cover back in the same way.

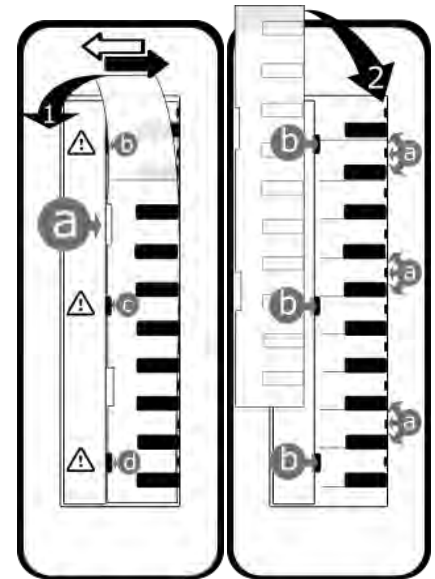

- **Premium Add-on 40 keys (with paper labels)**

- Remove the protective cover (1): Insert a thin object (or your fingernail) in the correct position (a) to lift the protective cover. Carefully remove the protective cover. The cover is held in place by small notches, take care not to break the plastic cover near the notches.
- Remove the paper label in the same way
- Replace the paper label and protective cover (2): The cover or the paper can only be placed in the right way. It has to cover all the paper area. If not, return it. Position the paper label, right side first, by inserting it under the plastic notches (c). Then, insert the other notches (b) by gently pressing the paper near each notch. Put the protective cover back in the same way.
- Follow the same method for each paper area.

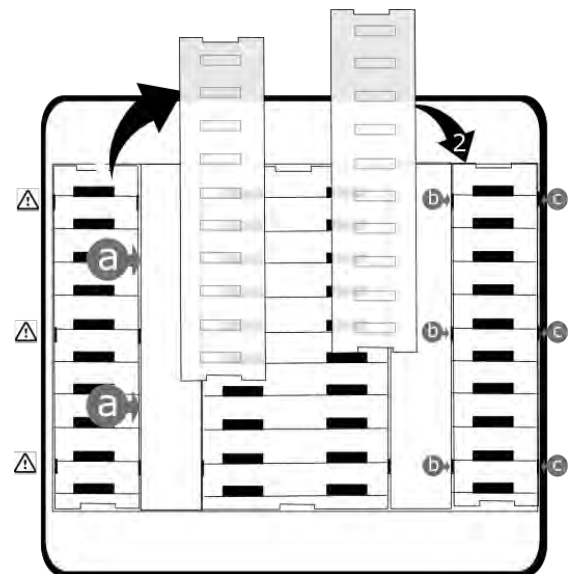

The application 'LabelSet' is available to help you to print the paper labels. Please contact your business partner for more information.

1.13ALE Wideband Bluetooth® Handset

The Bluetooth® Wireless handset is only available with compatible Bluetooth® deskphones.

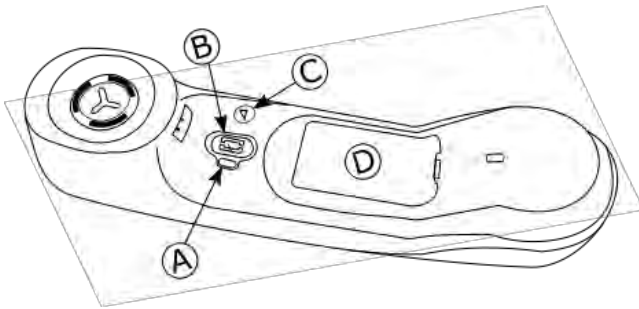

A	<p>LED (Front and back of the device)</p> <ul style="list-style-type: none"> • Blue flashing: Normal operation. • Blue steady: Handset charging. • Red slow flashing: Battery charge low. If voice prompts are enabled, you hear: "Battery low". • Red fast flashing: Handset outside coverage zone. If voice prompts are enabled, you hear: "Out of Range". • Red steady: handset not paired.
B	<p>Line key</p> <ul style="list-style-type: none"> • Switch the device on/off: Press and hold to switch the device on/off. If voice prompts are enabled, you hear: "Power On / Power Off". • Off-hook/On-hook: press this key to take or terminate a call. • Voice prompts (In idle state): Double press to enable the voice prompt.
C	<p>Volume/Mute key</p> <ul style="list-style-type: none"> • Volume (During conversation): Short successive presses to change the handset volume level (3 levels). • Mute (During conversation): Press and hold to ensure your correspondent no longer hears you. • Voice prompts (In idle state): Double press to disable the voice prompt.
D	<ul style="list-style-type: none"> • Location of the battery.

If the Bluetooth® handset is on its base, you do not need to press the Off-hook/On-hook key to take or terminate the call. Just off-hook/on-hook the Bluetooth® handset

The battery recharges when the Bluetooth® handset is on its base. The battery autonomy is more than 10 hours in conversation, and 50 hours in idle state. Charge the battery for about 6 hours before initial use.

If you are not going use the handset for a long time, we recommended that you switch off the device by using the switch at the top of the battery compartment.

1.13.1 Voice prompts

The voice prompts help you to manage functions of the handset. Voice prompts are available in 5 languages. The default language is English. To hear the prompt, the handset has to be near your ear. To select the next language, with the handset turned on, double press the 2 keys of the handset (B,C) at the same time. You hear the new selected language. Repeat until the desired language is reached.

To disable the voice prompts, with the handset turned on, double press the Volume/mute key (C). You are notified with a long beep. To enable the voice prompts, with the handset turned on, double press the Line key (B). You are notified with 2 short beeps.

1.13.2 Installing or replacing the Bluetooth® handset battery

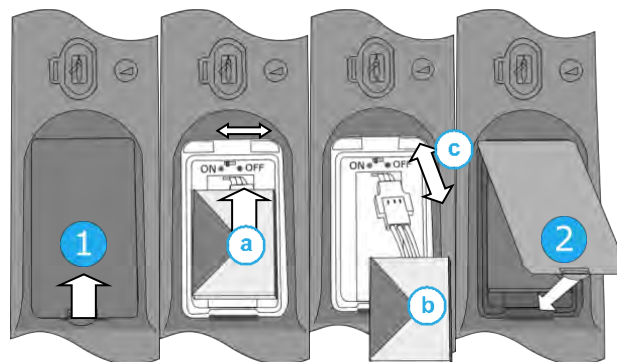

During the first use, to activate the battery, you have to set the switch to ON:

- 1- Lift up the battery cover.
 - a. Set the switch at the top of the compartment to ON using a pencil point.
- 2- Put the cover back on. Take care not to damage the cables when you put the cover on.

To replace the battery, with the handset turned off:



- 1- Lift up the battery cover.
 - a. Set the switch at the top of the compartment to OFF using a pencil point.
 - b. Lift up the battery using the tab to help you.
 - c. Disconnect the old battery and replace it with the new one by joining the 2 connectors. Arrange the battery, the cable and the connectors in the compartment.
 - a. Set the switch at the top of the compartment to ON using a pencil point.
- 2- Put the cover back on. Take care not to damage the cables when you put the cover on.

A spare battery can be ordered from your business partner.

1.13.3 Pairing and connecting the Bluetooth® wireless handset

This feature is only available with compatible Bluetooth® deskphone. Otherwise the corresponding menu is not displayed or is inactive.

Before the Bluetooth® handset can be used, it must be correctly paired to the terminal. Pairing will create a wireless link between the Bluetooth® wireless handset and the deskphone.

- 1- Set your deskphone to 'discover' the Bluetooth® wireless handset
 - Use one of the following:
 - 
 -  (long press) › *Bluetooth®*
 - *Search devices*
- 2- Put the handset in detectable mode
 - With the handset turned on, press and hold the 2 Bluetooth® handset keys (B, C) at the same time. If voice prompts are enabled, you hear: "Pairing mode, waiting for connection" ».

- 3- Connect the handset with the deskphone
- Searching for Bluetooth® equipment. Wait for the detected equipment type and address to be displayed.
 - Select the Bluetooth® wireless handset displayed in your deskphone: "ALE BT WB Handset".
 - Add the device by selecting the relevant menu on your deskphone (Depending on the deskphone).
 - If voice prompts are enabled, you hear: "Device connected". The 3-note tone indicates that the handset has been installed correctly. The LED flashes blue or red depending on the battery charge level.

The handset is correctly connected if it appears in the list of connected devices on your deskphone (see user manual of the deskphone). Press the Line key of the handset to test the connection, your deskphone prompts you to enter a number. Please contact your installer if you encounter any problems. Before contacting your installer make sure you have information such as the serial number, the date code and the technical reference that you can find on the battery.

1.14 ALE Bluetooth® Handset

The Bluetooth® Wireless handset is only available with compatible Bluetooth® deskphones.

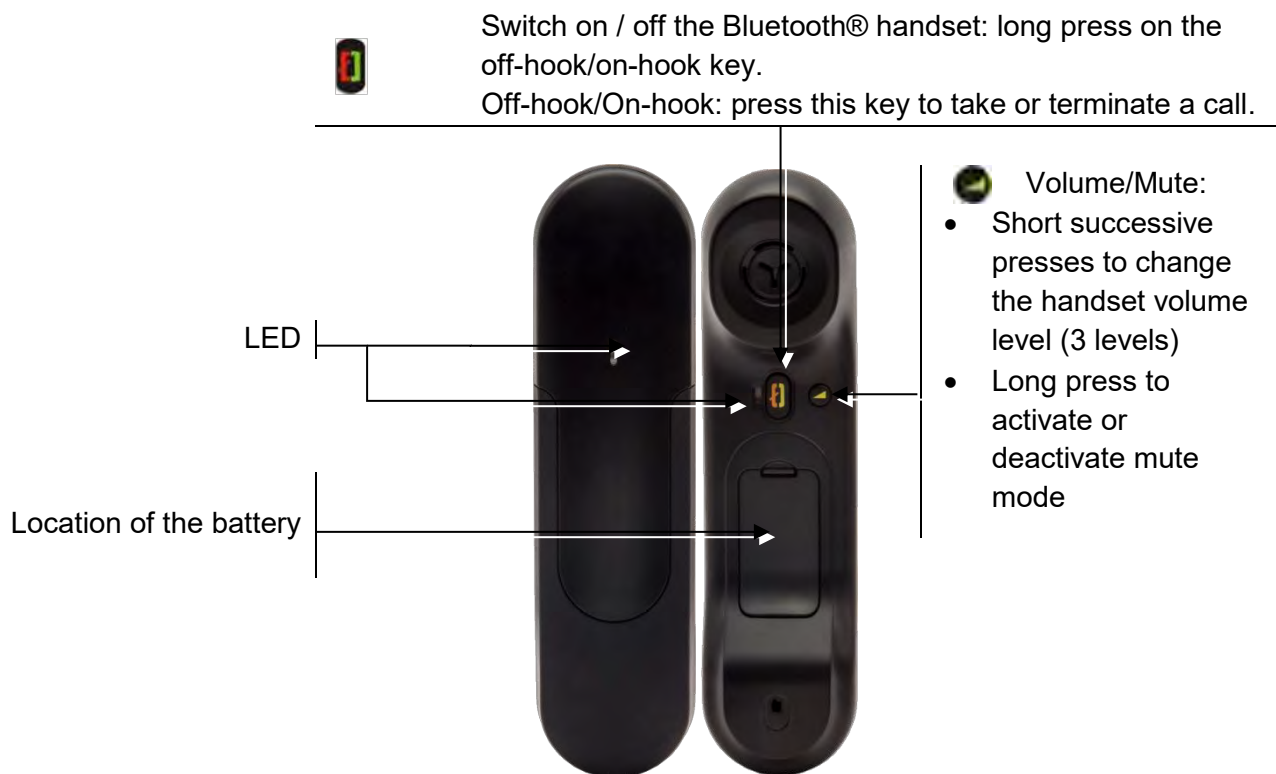

If the Bluetooth® handset is on its base, you do not need to press the Off-hook/On-hook key to take or terminate the call. Just off-hook/on-hook the Bluetooth® handset.

1.14.1 LED

- Off: operating normally.
- Green flashing: in communication.
- Green steady: handset charging.
- Orange flashing: battery charge low or handset outside coverage zone.
- Orange steady: malfunction.

If the Bluetooth® handset is on its base, you do not need to press the Off-hook/On-hook key to take or terminate the call. Just off-hook/on-hook the Bluetooth® handset.

1.14.2 Installing or replacing the Bluetooth® handset battery

At the first use, you have to connect the battery to the handset. The battery is placed in its compartment but it is not connected. To install a new battery, follow instruction:

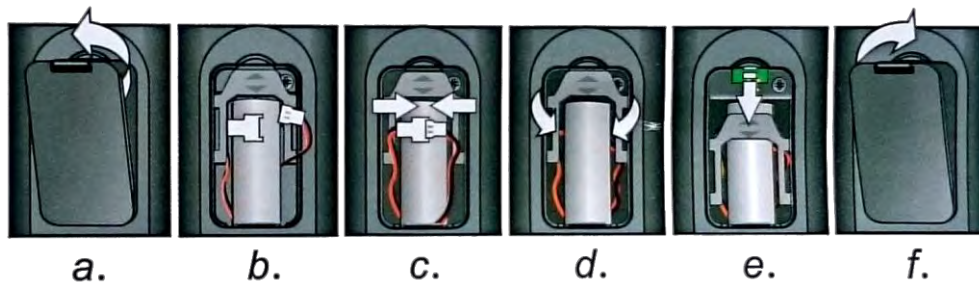

- a) Lift up the battery cover.
- b) Take the 2 connectors.
- c) Assemble the 2 connectors.
- d) Arrange the battery, the cable and the connectors in the battery compartment (place the connected side of the battery in the bottom of the compartment)
- e) Slide out the battery holding part.
- f) Replace the cover.

The battery recharges when the Bluetooth® handset is on its base.



Switch on / off the Bluetooth® handset: long press on the off-hook/on-hook key.

Defective batteries must be returned to a collection point for chemical waste disposal.

1.14.3 Pairing and connecting the Bluetooth® wireless handset

This feature is only available with compatible Bluetooth® deskphone. Otherwise the corresponding menu is not displayed or is inactive.

Before the Bluetooth® handset can be used, it must be correctly paired to the terminal.

- Use one of the following:
 - 
 -  (long press) › *Bluetooth®*
- *Search devices*
-  With the handset turned off, press the 2 Bluetooth® handset keys at the same time (long press).

›› You will hear a 3 note signal and the LED will flash green and orange alternately.

›› Searching for Bluetooth® equipment. Wait for the detected equipment type and address to be displayed.

- Select the relevant equipment: ALE BT Handset.
- *Add*
- Enter the PIN code of the device if necessary.
- *Confirm* ›› The 3-note tone indicates that the handset has been installed correctly. The LED flashes green or orange depending on the battery charge level.

Error messages

- The Bluetooth® handset emits a sequence of 4 beeps: Your set is an older generation than your Bluetooth® handset.
- The set displays an error message indicating that the set and the Bluetooth® handset are incompatible: Your Bluetooth® handset is an older generation than your set.

1.15 Install a comfort wired handset

You can install a wired handset in place of the Bluetooth® Wireless Handset.

- Remove the rubber.
- Plug-in the wired handset to the appropriate connector (refer to phone description).
- Make sure you position the cable correctly in the compartment intended for that purpose:-:
- Switch off the Bluetooth® Wireless Handset (press and hold the On/Off hook key until you hear distinct tones).



2 Using your telephone









2.1 Consulting the call log

At any time, you can consult all answered and unanswered incoming and outgoing calls.

-  *Call Log*

2.1.1 Consulting all calls

All calls are displayed with an icon giving information on the type of call.

		Answered outgoing calls.
		Unanswered outgoing calls.
		Answered incoming calls.
		Unanswered incoming calls.





- Scroll through the list by using the navigation keys (If more than one page).
- Display the contact information by selecting it in the list. Information such as the name, phone number, date and time are displayed on the screen.
- You can choose to call the contact or clear the log:
 - *Recall*: Call back the contact.
 - *Delete*: Delete the entry.
 - *Delete all*: Delete the entire log.

2.1.2 Delete all call logs

- Use one of the following:
 - Press the key associated with the icon: .
 - Display the contact information by selecting it in the list.
Delete all
- *Yes*: To confirm.
All call logs are deleted.

2.2 Making a call

Use one of the following:

- Dial the destination number. The hands-free mode is activated automatically.
- Unhook the handset › Dial the destination number.
- Press the Off-hook key of the headset › Dial the destination number. If your headset has no Off-hook/On-hook key, use the phone keys and switch on the audio on the headset ().
-  Press the on-hook/off-hook key of the Bluetooth® device (Bluetooth® Wireless handset) › Dial the destination number.
-  Hands-free › Dial the destination number.
- Programmed line key.
- Dial by name (enter the first letters of the contact's name on the alphapad and press OK to start the search).
-  Redialing from the call log.
-  Redial last number.

To make an external call, dial the outside line access code before dialing your contact number.

For the 8018 DeskPhone, the redial key is associated with the Off-hook key when the phone is in idle state: .







If the internal or outside number does not reply:

- *LS announce* › Broadcast a message on the loudspeaker of the free terminal.
- *Call back* › Request callback to a busy terminal.
- *Text mail* › Send a written message.
- *Voice mail* › Store number to call again.

The hands-free mode can be deactivated by the administrator.

2.3 Receiving a call





Use one of the following:

- Lift the handset to take the call.
- Use the headset to take the call. If your headset has no Off-hook/On-hook key, use the phone keys and switch on the audio on the headset (.
-  or  or  › Press the 'take the call', 'loudspeaker' or 'line key' key to take the call in hands-free mode.
- *Take call* or  › Take the call with the headset if connected, or in hands-free mode.
-   Select the incoming call icon.



The hands-free mode can be deactivated by the administrator.

2.4 Switching between audio modes

During the conversation, you can switch between different audio modes (handset, loudspeaker, hands-free or headset, if connected) by pressing the loudspeaker/hands-free key until the desired audio mode is displayed: . If you are in conversation using the handset, you can take the current call in hands-free mode or with the headset, and vice versa. The key is lit when the loudspeaker or hands-free mode is selected.

- Switching to the handset (short press): .
- Switching to the loudspeaker (long press):  (The key is lit).
- Switching to the hands-free (short press):  (The key is lit).
- Switching to the headset (short press): .









For each audio mode, during the conversation, you can adjust the volume by pressing the volume keys (number of levels: 7). The selected volume, for each audio mode, will be saved for future conversations.

- During a conversation.
-   Adjust volume by pressing the volume keys (number of levels: 7).

The hands-free mode can be deactivated by the administrator.

2.5 Activating the loudspeaker during a conversation (handset lifted) Loudspeaker.



Activate or deactivate the loudspeaker when you are in conversation using the handset or the headset.

-  Activate loudspeaker (long press)  The key lights up (.
-   Adjust volume by pressing the volume keys (number of levels: 7).
-  Deactivate loudspeaker (long press)  The key is no longer lit (.

Press and release the loudspeaker key to switch to hands-free mode (light steady).

2.6 Make calls by name (company directory)

123<>abc: If your set is not provided with a magnetic keyboard, use the alpha-numeric keyboard to enter letters. You have to switch the keyboard to the alphabetic mode by selecting the associated programmed key. When activated, the LED corresponding to the key remains lit up.

- Enter the lastname or initials or the lastname and first name of your contact.
- Select the type of search you want (last name, last name and first name or initials)  Display of all the contacts matching the search criteria.
- Use one of the following:
 -  Display the previous and next names.
 - Select the name of the person you wish to call.
 -  Modify the search.

*Name must be entered in format name / space / first name.

 This key is used to display the entire name when it is truncated (8078s, 8068s, 8058s, 8028s Premium DeskPhone).

2.7 Make calls via your programmed call keys

- Access the 'Perso' page.
-  Find the contact you want to call from the programmed call keys.
- Select the contact.

2.8 Redialing

2.8.1 Redialing the last number dialed (redial)

-  (short press)  Last number redial.

2.8.2 Call back one of the last 8 numbers dialed

-  (long press).
- Select the number to redial from the last 8 dialed number.

For the 8018 DeskPhone, the redial key is associated with the Off-hook key when the phone is in idle state: .

You can also access this feature through the menu:



- Reach the 'Menu' page.
- *Redial list*
- Select the number to redial from the last 8 dialed number.



: Press the key associated with the trash icon to delete the list of callback requests.

2.9 Callback requests

The messaging key flashes when you have a callback request.

-  The messaging key flashes when you have a callback request.
- *Callback / xx Callbacks*
-  Select a callback request in the list if there is more than one. If there is only one callback request, it is displayed directly.
- *Recall*

If there is only one callback request, it is displayed directly.





: Press the key associated with the trash icon to delete the list of callback requests.

2.10 Call back an unanswered call



2.10.1 Call back the last caller

- Reach the 'Menu' page.
- *Events*
- *Last caller >>* Call back the last caller.

2.10.2 List of last callers

- Use one of the following:
 -  *Non replied call / xx Non replied calls*
 - Reach the 'Menu' page.
Events
- Select the type of call:
 - *No non replied internal call / xx Non replied internal calls*
 - *No non replied external call / xx Non replied external calls*
-  Select a name or a number in the list if there are more than one. If there is only one name or number, it is displayed directly.
- *Recall*
- To delete the selected item.
- *Delete*

2.10.3 Delete the list of unanswered calls

- Use one of the following:
 -  *Non replied call / xx Non replied calls*
 - Reach the 'Menu' page.
Events
- Select the type of call:
 - *No non replied internal call / xx Non replied internal calls*
 - *No non replied external call / xx Non replied external calls*
- *Delete all* (or use icon: ).

2.11 Requesting automatic callback if internal number is busy

- Internal number busy.
- *Call back* >> Callback request acknowledged.
- 

2.12 Receiving interphony calls

You can answer a call without lifting the handset. When you receive a call, you are automatically connected in hands-free mode. The identity of the caller is displayed on the screen.

To activate Terminal idle:

-  >> Corresponding LED lights up.

When your caller hangs up, interphony mode remains active.

To deactivate Terminal idle:

-  >> The corresponding LED goes out.

2.13 Sending DTMF signals

During a conversation you sometimes have to send DTMF signals, such as with a voice server, an automated attendant or a remotely consulted answering machine.

Depending on the system configuration, the DTMF can be activated by default.

If DTMF is not activated by default on your system:

- During a conversation.
- Use one of the following:
 - *Send DTMF*
 - Press the star key.
- Enter DTMF code.

The function is automatically cancelled when you hang up.

If DTMF is activated by default on your system:





- During a conversation.
- Enter DTMF code.

If DTMF is activated by default on your system, you have to deactivate DTMF before entering the code of a feature: *Deactivate DTMF (Deact DTMF)*.



2.14 Mute, so that your contact cannot hear you

You can hear your contact but he/she cannot hear you:

2.14.1 From the set

- During a conversation.
-  Disable microphone >> The key lights up .
-  Resume the conversation >> The key is no longer lit .

2.14.2 From the Bluetooth® handset (Bluetooth® wireless handset)

-  Press the handset volume/mute key (long press).
-  Resume the conversation

2.14.3 From the headset

- Use the mute key of the headset, if there is one, to disable headset microphone or to resume the conversation

3 During a conversation

3.1 Making a second call during a conversation

- During a conversation.
- *New call* >> The first call is on hold.
- Number of second contact.

3.1.1 Other methods for calling a second contact

- Dial directly the number for your call.
- Name of second contact.
-  Select the 'Redial' function.
- Programmed line key.

3.1.2 Release the second call and recover the call on hold



- You are in conversation with the second contact and the first one is on hold.
- Use one of the following:
 - *Enquiry off*
 -  Hang up, your phone is ringing, then answer the call.
- You are on the line with your first contact.

To leave your two contacts talking together





-  Hang up.

If you make an error, hang up: your telephone will ring and you will recover your first call.

3.2 Answering a second call during a conversation

- During a conversation, another person is trying to call you >> Name or no. of the caller displayed for 3 seconds.
- Use one of the following methods to answer the displayed call (Multiline set).
 -   Select the incoming call icon.
 - *Take call*
- The first call is on hold.

To return to your first contact and end the conversation in progress.

-  >> The second call is ended.
- To return to the first contact, use one of the following.
 -   Select the incoming call icon.
 - 
 - Lift the handset.

3.3 Switching between calls (Broker call)

This feature depends on your system.

During a conversation, a second call is on hold.

Use one of the following:

-  Select the call on hold icon from the conversation screen.
- Select the tab which is displaying the call on hold › *Retrieve*
- Press the Back/Exit key to display the Perso page › Select the call on hold.

›› Your first call is placed on hold.

3.4 Transferring a call

3.4.1 To transfer your call to another number

- Calling a second person during a conversation ›› The first call is on hold.
- You can transfer the call immediately or wait for your contact to answer before transferring the call: *Transfer*

Transfer between two outside calls is not generally possible (depends on country concerned and system configuration).

3.5 Three-way conference with internal and/or external contacts (conference)

- During a conversation, a second call is on hold.
- *Conference (Confer)* ›› You are in conference mode.

3.5.1 Cancel conference and return to first contact (If conference is active)

- *End conference (End conf)*

3.5.2 Hang up on all participants (If conference is active)

-  Hang up.
- You exit the conference.

3.5.3 After the conference, to leave your two contacts talking together:

- *Transfer*
-  Hang up.

3.5.4 View information about the other people in the conference

-  Navigate between both call in progress tabs involved in the conference.

3.6 Talk simultaneously to more than 2 contacts

This feature depends on the system configuration. If necessary, contact your administrator.

You are in a conference call with 2 contacts. To add another participant to the conference:



- *Add*
- Dial the number of your contact (dial, directories, last numbers dialed...).
- Your contact answers.
- *Insert* ›› You are on the line with the additional contact.

During a 3-way conference, you can add up to three additional participants.

3.7 Placing a call on hold (hold)



3.7.1 Exclusive hold

During a conversation, you wish to place the call on hold and recover it later, on the same telephone.

- During a conversation.
-  Select the incoming call icon.
- Your call is placed on hold  .

Recover the call on hold:

Use one of the following:

- Hang up, your phone is ringing, then answer the call.
-   Select the call on hold icon from the conversation screen.
- Select the tab which is displaying the call on hold [› Retrieve](#)
- Press the Back/Exit key to display the Perso page [› Select the call on hold.](#)

3.7.2 Common hold

This feature depends on the system configuration. If necessary, contact your administrator.

Common hold allows to all sets in the same pick-up group to resume a call (internal or external) that has been put on hold by one of the members of that group.

Putting on common hold:

- During a conversation.
-  Press the Back/Exit key to display the Perso page.
- Press programmed key: [Comm hold](#) (by default).

Recover the call on hold from any sets defined in the same pick-up group (including your set):

- Recover the call on hold from any sets defined in the same pick-up group (including your set)
- Press programmed key: [Comm hold](#) (by default).

3.8 Placing an outside call on hold (parking)

You can place an outside call on hold and recover the call on another telephone:

- During a conversation.
- [Park the call](#)
- Enter the number of the parking destination phone.

Retrieve the call from the parking destination phone:

- Reach the 'Menu' page.
- [Settings](#) [› My services](#) [› Consult](#) [› Call pick up services](#) [› Park/retrieve call](#)

Retrieve the call from another phone:

- Reach the 'Menu' page.
- [Settings](#) [› My services](#) [› Consult](#) [› Call pick up services](#) [› Park/retrieve call](#)
- Enter the number of the parking destination phone.

This feature is accessible via a programmed key.

If the parked call is not recovered within a preset time (default value 1 min 30), it is transferred to the operator.

3.9 Intrusion into an internal conversation (barge-in)

Your contact's line is busy. If the number is not 'protected' and if authorised, you can intrude into the call:

- *Intrusion*
- Same key to exit (*Intrusion*).

3.9.1 Protect a call against intrusion

- Press programmed key. The programmed key has to be configured by the system (By default: No intrud).
- Enter contact's number.

Protection is cancelled when you hang up.

3.10 Signal malicious calls

This key lets you signal a malicious call. If this call has an internal source, it is signalled to the system by a special message.

- You receive a malicious call.
- *Malicious*

4 Sharing

4.1 Answering the general bell

When the operator is absent, outside calls to the operator are indicated by a general bell. To answer:

- Reach the 'Menu' page.
- [Settings](#) › [My services](#) › [Consultation](#) › [Call pick up services](#) › [Night service call pick up](#)

4.2 Manager/Assistant filtering

System configuration allows 'Manager/Assistant' groups to be formed, so that the manager's calls can be directed to one or more assistants.

the programmed key has to be configured by the system.

From the manager or assistant telephone

- Press programmed key >> Incoming calls are filtered by a chosen person (assistant, etc.).
- Same key to cancel.

Filtering is indicated on the manager's telephone by the icon corresponding to the 'screening' programmed key.

4.3 Call pick-up

You hear a telephone ringing in an office where no-one can answer. If authorised, you can answer the call on your own telephone.

The system can be configured to prevent call pick-up on certain telephones.

If the telephone ringing is in your own pick-up group

- Reach the 'Menu' page.
- [Settings](#) › [My services](#) › [Consultation](#) › [Call pick up services](#) › [Group call pick up](#)

This feature is accessible via a programmed key: *GpPickUp* (by default).

If the telephone ringing is not in your pick-up group

- Reach the 'Menu' page.
- [Settings](#) › [My services](#) › [Consultation](#) › [Call pick up services](#) › [Individual call pick up](#)
- Number of telephone ringing

This feature is accessible via a programmed key: *Pick up* (by default).

4.4 Hunting groups

Hunting group call:

Certain numbers can form a hunting group and can be called by dialling the group number.

Temporary exit from your hunting group:

- Reach the 'Menu' page.
- [Settings](#) › [My services](#) › [Consultation](#) › [Additional services](#) › [Go out of hunting group](#)
- Enter your group number

This feature is accessible via a programmed key: *In group* (by default).

Return into your group:

- Reach the 'Menu' page.
- [Settings](#) › [My services](#) › [Consultation](#) › [Additional services](#) › [Go into hunting group](#)
- Enter your group number.

This feature is accessible via a programmed key: *Out grp* (by default).

Belonging to a group does not affect the management of direct calls. A specific telephone within a group can always be called by using its own number.

4.5 Calling an internal contact on his/her pager

The number called does not answer and you know that the person called has a pager:

- Dial the destination number.
- [Paging](#)
- Dial the destination number ›› Paging in progress is displayed.

Your contact can answer from any telephone in the system.

4.6 Answering a call on your pager

A call on your pager can be answered from any telephone within the system.

- Your pager beeps.
- Reach the 'Menu' page.
- [Settings](#) › [My services](#) › [Consultation](#) › [Paging services](#) › [Paging answer](#)
- Your extension number.

This feature is accessible via a programmed key: *PagAnsw* (by default).

4.7 Calling a contact on his/her loudspeaker

Your internal contact does not answer. If authorised, you can remotely activate her/his phone:

- Your contact does not reply.
- [LS announce](#) ›› You are connected to the loudspeaker on your contact's phone (if he/she has the hands-free function).

4.8 Sending a written message to an internal contact

123<>abc: If your set is not provided with a magnetic keyboard, use the alpha-numeric keyboard to enter letters. Use the alpha-numeric keyboard key to switch between the numeric and alphabetic keyboard. When in alphabetic mode, the LED corresponding to the key remains lit up.

- 
- *Text mail* >> *Send*
- Use one of the following:
 - Enter the number of the terminal to receive the message.
 - Enter the first letters of the name.
- Choose the type of message.

Sending predefined message

- *Predefined msg*
- Select a predefined message.
- *Apply*

Sending a message to complete

- *To complete*
- Select a predefined message to complete.
- Complete your message.
- *Apply*

Sending a new message



- *To create*
- Write your message.
- *Apply*

Sending the previous message



- *Previous msg*
- *Apply*

4.9 Consulting written messages



The light indicates that messages have been received.

-  >> Number of messages received.
- *New text message* > *Read message (Read msg)* >> Display name of sender, with date, time and ranking of message.
- Use one of the following:
 - *Scroll message (Scroll msg)* >> Scroll through the messages.
 - *Next message (Next msg)* >> Next message.
 - *Delete* >> Delete messages.
 - *Recall* >> Call back sender of message.
 - *Text answer (Answer txt)* >> Answer with a text message.
 -  >> Terminate consultation.

4.10 Send a voice message copy

- 
- *Voice mail / new voice message / x new voice messages*
- Enter your personal code >> Display number of new and old messages.
- *Consult > Forward msg*
- Number to be called /contact's name (*Spell name* / ).
- *Send >>* Send message.
- *Exit >>* End of broadcast.

4.11 Sending a recorded message to a number or a distribution list

- 
- *Voice mail / new voice message / x new voice messages*
- Enter your personal code >> Display number of new and old messages.
- *Send*
- Record your message.
- *Exit >>* End of recording.
- Number to be called /contact's name (*Spell name* / ).
- *Send >>* Send message.
- *Exit >>* End of broadcast.

4.12 Broadcasting a message on the loudspeakers of a station group

A message not requiring an answer can be broadcasted on the loudspeakers within your broadcast group:



- Off hook.
- Number of broadcast group >> Speak, you have 20 seconds.
-  Hang up.

The message will only be broadcast on terminals not in use and which have a loudspeaker.

5 Keep in touch

5.1 Forwarding calls to another number (immediate forward)



The number can be your home, mobile, voice mailbox or an internal extension (operator, etc.).

- Select the forward icon (the icon depends on your phone:  / .
- *Immediate forward (Immediate / Imm fwd / Immediate fwd)*
- Number to be called >> Forward is acknowledged.
- 

You can make calls, but only the destination number can call you.



If the associated number is defined, you can directly select it as the forwarding destination.

5.2 Forwarding calls to your voice message service

- Select the forward icon (the icon depends on your phone:  / .
- *Imm fwd to VM (Imm fwd)* >> Forward is acknowledged.
- 

5.3 Forwarding calls if you do not answer or if you are busy

When you are absent or already in communication (all lines are busy), all your calls are forwarded to the defined number.



- Use one of the following:
 - Select the forward icon (the icon depends on your phone:  / .
 - Reach the 'Menu' page > *Forward*
- *Other forward (Other fwd)*
- Select the forward type to program.
 - *Forward on busy*
 - *Forward on no reply*
 - *Forward on busy/no reply*
- Number receiving forward >> Diversion is acknowledged.

If you have a key programmed with this feature, you can access the feature directly.

- Press programmed key.
- Number receiving forward >> Diversion is acknowledged.

5.4 When you return, consult recorded messages

The message key flashes when you have received a new voicemail, text message or callback request and is lit if you have missed calls.

- 
- *new voice message / x new voice messages*
- Enter your personal code **>>** Display name of sender, with date, time and ranking of message.
- *Consult* **>>** Listen to message.
- When you have listened to the message, do one of the following.
 - *Replay* **>>** Replay message.
 - *Erase* **>>** Erase message.
 - *Call sender* **>>** Call back sender of message.
 - *Forward msg* **>>** Forward the message to another contact.
 - *Save* **>>** Archive the message.
 -  *Exit* **>>** Terminate consultation.



5.5 Forwarding calls to your pager

Callers will thus be able to contact you while you are moving around the company

- Press programmed key (The programmed key has to be configured by the system) **>>** Forward is acknowledged.

5.6 Forwarding your calls from the receiving terminal ('Follow me')

You wish to receive your calls in your present location: Use the 'Follow me' function.

- Select the forward icon (the icon depends on your phone:  / .
- *Other forward (Other fwd) > Remote forward*
- Enter the number of the phone you want to receive calls.
- Enter the number of the phone you want to forward calls.



>> Forward is acknowledged.

If you have a key programmed with this feature, you can access the feature directly.



- Press programmed key.
- Dial your extension number **>>** Forward is acknowledged.

If the associated number is defined, you can directly select it as the forwarding destination.



Cancel call forwarding from the forwarding phone

- Select the forward icon (the icon depends on your phone:  / .
- *Deactivate*

Cancel call forwarding from the destination phone

- Select the forward icon (the icon depends on your phone:  / .
- *Other forward (Other fwd) > Deactive follow me*
- Enter the forwarded phone number.

Cancel call forwarding from an another terminal in your system

- Select the forward icon (the icon depends on your phone:  / .
- *Other forward (Other fwd) > Deactivate remote forward*
- Enter the forwarded phone number.



5.7 Applying a selective forward

You can forward your primary number and your secondary number or numbers to different sets.

- Reach the 'Menu' page.
- *Settings* > *My services* > *Consultation (Consult)* > *Additional services*
- Select the number to forward.
 - *Principal line selection*
 - *Second line selection*
- *Apply*
- Enter the number of the phone you want to receive calls.
- The destination number of the forward is called.
- 

5.8 Do not disturb



You can make your terminal temporarily unavailable for all calls.

- Select the forward icon (the icon depends on your phone:  / ).
- *Do not disturb (Not disturb)*
- Enter code to activate the feature.
- *Apply* >> Forward is acknowledged.

Callers wishing to contact you will see the 'Do Not Disturb' message displayed on their sets when they try to call.

To deactivate the Do not disturb feature, follow the same procedure.

5.9 Cancelling all forwards

- Use one of the following:
 - Select the forward icon (the icon depends on your phone:  / .
 - Reach the 'Menu' page > *Forward*
- *Deactivate*

To cancel all forwards, you can programme another type of forward too.

5.10 Leaving a recorded message for internal callers

123<>abc: If your set is not provided with a magnetic keyboard, use the alpha-numeric keyboard to enter letters. You have to switch the keyboard to the alphabetic mode by selecting the associated programmed key. When activated, the LED corresponding to the key remains lit up.

You can leave a message on your terminal which will be displayed on the screen of the terminal calling you.

- 
- *Text mail /new text message / x new text messages*
- *Fwd to text*
- Choose the type of message.

Sending predefined message

- *Predefined msg (Predefined)*
- Select a predefined message.
- *Apply*

Sending a message to complete

- *To complete*
- Select a predefined message to complete.
- Complete your message.
- *Apply*

Sending a new message

- *Msg to create (To create)*
- Write your message.
- *Apply*

To deactivate the forward to text feature

- 
- *Text mail /new text message / x new text messages*
- *Deactfwdtext >>* The text message is displayed.
- *Deactivate*

6 Managing your charges

6.1 Charging your calls directly to business accounts

You can charge the cost of your outside calls to business account numbers.

- Reach the 'Menu' page.
- [Settings](#) › [My services](#) › [Consultation](#) › [Additional services](#) › [Business account code](#)
- Number of business account.
- Number required.

6.2 Finding out the cost of an outside call made for an internal user from your terminal

- Reach the 'Menu' page.
- [Settings](#) › [My services](#) › [Consultation](#) › [Consultation & callbacks](#) › [Charging informations](#)

7 Programming your telephone

7.1 Initializing your voice mailbox

- Light flashes.
- 
- Enter your personal code then record your name according to voice guide instructions.

Your personal code is used to access your voice mailbox and to lock your telephone.

A weak personal code will be rejected by the system:

- Identical 4 digits (0000, 1111,).
- A simple sequence of 4 digits (0123, 1234,).

Make sure you choose a strong password with at least 4 digits. The list of weak passwords provided does not contain all the possibilities.

7.2 Customizing your voice greeting

You can replace the greeting message by a personal message.

- 
- *Voice mail / new voice message / x new voice messages*
- Enter your personal code.
- *Perso options* › *Greeting msg* › *Perso greeting* ›› Record message.
- *End* ›› End of recording.
- Use one of the following:
 - *Accept* ›› Apply.
 - *Restart* ›› Re-record a message.
 - *Replay* ›› Replay message.

To return to the default message.

- *Normal prompt*

7.3 Modify the password for your phone set

- Reach the 'Menu' page.
- *Settings* › *Phone* › *Password*
- Old code (4 digits).
- *Apply*
- New code (4 digits).
- *Apply*
- Enter new password again to confirm.
- *Apply*
- 



This code acts as a password controlling access to programming functions and the user 'Set Locking ' function (code by default: 0000).

A weak personal code will be rejected by the system:

- Identical 4 digits (0000, 1111,).
- A simple sequence of 4 digits (0123, 1234,).

Make sure you choose a strong password with at least 4 digits. The list of weak passwords provided does not contain all the possibilities.

7.4 Modify the password for your voice mailbox

- 
- *Voice mail / new voice message / x new voice messages*
- Enter your personal code.
- *perso options › Admin options › Password › My password*
- New code (4 digits).
- *Apply*
- 

As long as your voice mailbox has not been initialized, personal code is 0000.

A weak personal code will be rejected by the system:



- Identical 4 digits (0000, 1111,).
- A simple sequence of 4 digits (0123, 1234,).

Make sure you choose a strong password with at least 4 digits. The list of weak passwords provided does not contain all the possibilities.

7.5 Adjusting the audio functions



- Reach the 'Menu' page.
- *Settings › Phone › Ringing*
- Enter your password (if required) and apply.

7.5.1 Choose the tune

- Select the type of call to which the ringing is to be associated.
 - *Internal call (Internl call)*
 - *External call (Externl call)*
- Select the melody of your choice (17 tunes).
- 
-  End
-  To adjust other audio features.



Of the ringers, one ringer is louder than the others and can be used in noisy environments.

7.5.2 Adjusting the ringer volume



- *Level*
-  Select the volume you want (12 levels).
-  End.
-  To adjust other audio features.

Of the ringers, one ringer is louder than the others and can be used in noisy environments.



7.5.3 Activate/deactivate silent mode

- *More options*
 - *Silent mode ››* To activate.
 - *Silent mode ››* To deactivate.
-  End
-  To adjust other audio features.



7.5.4 Activate/deactivate meeting mode (progressive ringing)

- *More options*
 - *Progressive ringing* >> To activate.
 - *Progressive ringing* >> To deactivate.
-  End.
-  To adjust other audio features.

7.5.5 Activate/deactivate discreet ring mode

- *One beep before ringing* / *Three beeps before ringing* >> To activate.
- *One beep before ringing* / *Three beeps before ringing* >> To deactivate.
-  End.
-  To adjust other audio features.

7.5.6 Adjust ringer volume while a call arrives

- Your telephone rings.
-   Adjusting the ringer volume.



7.6 Adjusting the brightness of the deskphone (8078s, 8068s, 8058s, 8028s Premium DeskPhone)

Adjust the brightness of the display, the LEDs, the keys (add-on) and the logo light on the back shell (optional).

7.6.1 Auto-adjusting of the brightness

The phone can automatically adjust the display brightness, LED and busy light logo on the back shell (if present) depending on the lighting conditions to improve user experience and achieve power savings (ambient light sensor).







Auto-adjusting of the display brightness

-  or  (long press) > *Display* > *Auto-Brightness*
- Activate or deactivate the feature.







Auto-adjusting of the LED brightness and the busy light logo on back shell (if present)

-  or  (long press) > *Display* > *Advanced* > *LED brightness auto*
- Activate or deactivate the feature.







7.6.2 Adjust the brightness when the phone is in use

-  or  (long press) > *Display* > *Brightness*
-   Increase or decrease the brightness.
- 
- 





7.6.3 Adjust the dimmed brightness when the phone is not in use

-  or  (long press) > *Display* > *Advanced* > *Low brightness*
-   Increase or decrease the brightness.
- 
- 

7.6.4 Set the delay before the brightness is dimmed when the phone is not in use (screensaver)



-  or  (long press) › *Display* › *Screensaver*
-   set the time delay (default 4 hours).
- 
- 

7.7 Adjusting the contrast of the display (8028s, 8018)



- Reach the 'Menu' page.
- *Settings* › *Phone* › *Contrast*
-   Decrease or increase the contrast of the display.
- 
- 

7.8 Selecting the welcome page

This function is used to choose the page displayed by default on the telephone.

- *Settings* › *Phone* › *Homepage*
- Select the default page (Menu, Perso, Info, Last page seen...).
- 
- 

7.9 Selecting language

- Reach the 'Menu' page.
- *Settings* › *Phone* › *Language*
- Select the language of your choice.
- 
- 

7.10 Programming keys for call numbers and functions (Perso page/F1 and F2 keys/add-on keys)

123<>abc: If your set is not provided with a magnetic keyboard, use the alpha-numeric keyboard to enter letters. Use the alpha-numeric keyboard key to switch between the numeric and alphabetic keyboard. When in alphabetic mode, the LED corresponding to the key remains lit up.

Depending on your deskphone, you can program:

- Softkeys of the Perso page.
 - Keys/softkeys of the add-on module.
 - F1 and F2 keys.
 - Programmable keys with LED and paper.
 - Programmable keys with LED and paper.
- Led behavior may differ depending on the system configuration. For more information, contact your installer or administrator.

If the key is not programmed yet:

- Select the key to program.
- Enter your password (if required) and apply.
- Use one of the following:
 - *Speed dial* >> To program a number.
 - *Services* >> To program a function.

If the key is already programmed:

- Use one of the following:
 - 
 - Reach the 'Menu' page > *Settings* > *Phone* > *Key program* > *Prog perso page*
- Select the key to program.
- Enter your password (if required) and apply.
- Use one of the following:
 - *Speed dial* >> To program a number.
 - *Services* >> To program a function.

To program a number

- *Speed dial*
- Enter the number.
- *Apply*
- Enter the name of the key.
- *Apply*
- 



To program a function

- *Services* >> Follow information displayed on the screen.
- 



7.10.1 Other possibilities

- *Modify* >> Modify contents of entry displayed.
- *Erase* >> Delete

7.11 Modify a programmed key

- Use one of the following:
 - 
 - Reach the 'Menu' page > *Settings* > *Phone* > *Key program* > *Prog perso page*
- Select the key to modify.
- Enter your password (if required) and apply.
- *Modify*
- 

7.12 Delete a programmed key

- Use one of the following:
 - 
 - Reach the 'Menu' page > *Settings* > *Phone* > *Key program* > *Prog perso page*
- Select the key to delete
- Enter your password (if required) and apply.
- *Delete (Clear)*
- 

7.13 Programming an appointment reminder

You can define the time of a temporary reminder (one in 24 hours).

- Reach the 'Menu' page.
- *Appointment*
- Enter time of appointment.
- Dial the number of the appointment destination set.



 The 'Appointment programmed' icon is displayed on the welcome page of the phone that will be alerted.

At the programmed time, your phone rings:

-  / 

If your calls are forwarded to another terminal, the forward is not applied to the reminder call.

To cancel your reminder request:

- Reach the 'Menu' page.
- *Appointment* > *Delete*



The 'Appointment programmed' icon disappears from the welcome page.

7.14 Identify the terminal you are on

The number of your telephone is displayed on the 'Info' page.

7.15 Lock / unlock your telephone

 This icon indicates that the phone is locked.

- Reach the 'Menu' page.
- *Lock*
- Enter your password >> Your telephone is locked/unlocked.



7.16 Install a jack accessory (headset, hands-free, loudspeaker) (8078s, 8068s, 8058s, 8028s Premium DeskPhone)

By default, the audio jack of your telephone can be used to connect a headset, hands-free kit or loudspeaker. A wideband headset can also be installed for optimized sound quality.



When you plug the jack accessory in the jack, a popup asks you for the type of accessory:

- *Headset*
- *Handsfree*
- *Loudspeaker*

If another headset is already connected (USB or Bluetooth® if available), a popup asks you to select your preferred headset.

A specific icon is displayed in the status bar: .

If necessary, you can also select the accessory type in the audio settings:



-  or  (long press) › *Audio*
- *Jack config.*
- *Headset / Handsfree / Loudspeaker* › Select the type of device plugged into the jack.
- 

Your phone is equipped with a 3.5 mm, 4 pole jack. If your device is not compatible, you can use a 3 pole to 4 pole jack adapter.

7.17 Install a USB accessory (Headset, Handsfree, Loudspeaker)



- Connect the accessory to the USB connector.
- When you plug the accessory in the USB port, the USB accessory is automatically detected. If an another accessory is already connected with the same function (USB, jack or Bluetooth® if available), a popup asks you to select your preferred accessory to use for this function.



If necessary, you can also select the accessory type in the audio settings:

-  or  (long press) › *Audio*
- *Devices*
- The list of connected devices is displayed.
- Select the type of device connected to the USB.
 - *Headset*
 - *External hands-free*
 - *External loudspeaker*
- 

7.18 Manage connected devices



7.18.1 List of connected devices

-  or  (long press) › *Audio*
- *Devices*
- The list of connected devices is displayed. You can find information about the connector:

-  : USB.
-  : Jack.

7.18.2 Default device

If you have connected the same type of accessory onto different connectors (for example, one headset to the jack connector, one headset to the USB connector and one Bluetooth® headset), the list of used connectors is display for each type of accessory. You can select your preferred accessory to be used as the default accessory.

-  or  (long press) › *Audio*
- *Devices*
- The list of connected devices is displayed.
- Select the device with more than one connector icons.
- Select your preferred accessory

7.19 Call the associated set

The number of another set can be associated with your set number (See Modify the associated number). To call it:

- Reach the 'Menu' page.
- [Settings](#) › [My services](#) › [Consultation \(Consult\)](#) › [Associate services](#) › [Call associate](#)

7.20 Forward your calls to the associated number

If you have previously defined an associated number, you can forward your calls to this number.

- Reach the 'Menu' page.
- [Settings](#) › [My services](#) › [Consultation \(Consult\)](#) › [Associate services](#)
- Use one of the following:
 - [Overflow to associate](#) ›› For forwarding when you do not answer.
 - [Overflow if busy to associate](#) ›› For immediate forwarding when your line is busy.
 - [Overflow busy/no rep to assoc](#) ›› For forwarding if you do not answer or if you are busy.
 - [Deact overflow to associate](#) ›› To cancel the forwarding to associate function.
- [Apply](#)

7.21 Modify the associated number

The associated number can be a phone set number, the voice mail number or the pager number.

- Reach the 'Menu' page.
- [Settings](#) › [My services](#) › [Associate](#)
- Enter your password.
- [Apply](#)
- [Modify](#)
- Select the new associated number.
 - Enter the new associated number.
 - [Speed dial](#)

7.22 The Tandem configuration

This configuration lets you group sets under a single phone number. Your set is then the main set and the other sets, usually a DECT, a remote extension, a DeskPhone or softphone, are secondary sets. Each set has its own directory number, but the tandem number is that of the main set. When you receive a call, all sets ring simultaneously. When one of the sets answers, the other sets stop ringing. When all the lines of the main set are busy, the secondary sets did not ring. A secondary set can still be called by its own number, but in this case, the tandem function will no longer be taken into account. Most of the functions are common to all sets, for example: forwarding, meet-me reminder, the various messages, etc., while others are specific to each set, for example: individual directory, last number redial, out of service, locking, etc. Tandem mode supports up to 4 secondary devices.

For more information regarding this configuration, contact the person in charge of your installation.

7.23 Create, modify or consult your interphony list (max. 10 numbers)

- Reach the 'Menu' page.
- [Settings](#) › [My services](#) › [Interphony](#)
- Enter your password.
- Select an entry.
- Follow the on-screen instructions.

7.24 Installing and using an ALE Bluetooth® wireless handset

This feature is only available with compatible Bluetooth® deskphone. Two Bluetooth® handsets are provided by ALE International.

Please consult the following chapter depending on the handset in your possession (grey or color buttons):

- ALE Wideband Bluetooth® Handset.
- ALE Bluetooth® Handset.

7.25 Installing a Bluetooth® Wireless Technology headset (pairing)



This feature is only available with compatible Bluetooth® deskphone. Otherwise the corresponding menu is not displayed or is inactive.

A multi-point Bluetooth® headset can be provided by ALE International.

This headset can be paired to your mobile phone and other communication devices at the same time. For example, you can use the headset paired to your mobile and when you enter your office the headset automatically matches to your office set too.

You can then answer a call using your Bluetooth® headset or the Bluetooth® Handset on the office set.

Before a Bluetooth® headset can be used, it must be correctly paired to the terminal. Before performing the pairing operation, the headset must be in detectable mode.

- Use one of the following:
 - 
 -  (long press) › *Bluetooth®*
- *Search devices*

›› Searching for Bluetooth® equipment. Wait for the detected equipment type and address to be displayed

- Select the relevant equipment.
- *Add*
- Enter the PIN code of the headset*.
- *Confirm* ›› Acknowledgement message and display of the headset icon on the terminal screen.

*Refer to the user documentation supplied with the headset.



7.26 Using a Bluetooth® Wireless Technology headset

This feature is only available with compatible Bluetooth® deskphone. Otherwise the corresponding menu is not displayed or is inactive.

Refer to the user documentation supplied with the headset.

7.27 Display all paired Bluetooth® devices



This feature is only available with compatible Bluetooth® deskphone. Otherwise the corresponding menu is not displayed or is inactive.

- Use one of the following:
 - 
 -  (long press) › *Bluetooth®*
- *Devices*

›› Display of the different equipment paired.

7.28 Removing a Bluetooth® accessory (headset, handset, etc.)

This feature is only available with compatible Bluetooth® deskphone. Otherwise the corresponding menu is not displayed or is inactive.

- Use one of the following:
 - 
 -  (long press) › *Bluetooth®*
- *Devices*

›› Display of the different equipment paired.



- Select the equipment to be removed.
- *Remove*
- 

›› Message acknowledging the equipment has been removed.

7.29 Pair your phone as a Bluetooth® device

This feature is only available with compatible Bluetooth® deskphone. Otherwise the corresponding menu is not displayed or is inactive.

Your phone can be used as a Bluetooth® device (loudspeaker for example). Before performing the pairing operation, your phone must be in detectable mode.

- Use one of the following:
 - 
 -  (long press) › *Bluetooth®*
- *Parameters*

›› Display of the different equipment paired. A specific icon is displayed on the screen .

7.30 Configure your phone for teleworking

Your IP phone is compatible with teleworking (VPN) via a secure connection (encrypted). In this mode, all features available at your office will be ready for use remotely.

If the telephone system of your enterprise is configured to accept remote workers (system and infrastructure), you have to configure your deskphone to be ready for teleworking. Your installer has to give you all information to configure your deskphone.

You have to:

- Enable VPN.
- Enter the remote VPN server information.
- Enter the TFTP server information (optional).
- Enter authentication.
- Setup the VPN start preferences.

7.30.1 First connection as teleworking

When you connect your deskphone for the first time remotely, you are prompted to set a PIN code. The PIN code is requested when you enter in the VPN configuration (submenus) or when you boot your deskphone (depending on the VPN configuration).



The PIN code is retained during the session so that you can access the VPN configuration without having to re-enter your PIN code until you exit the VPN configuration.

Before configuring your phone for teleworking, check if you have all the information from your administrator.

123<>abc: If your set is not provided with a magnetic keyboard, use the alpha-numeric keyboard to enter letters. Use the alpha-numeric keyboard key to switch between the numeric and alphabetic keyboard. When in alphabetic mode, the LED corresponding to the key remains lit up.

To configure your deskphone:

- Connect your deskphone to the network (and plug in the power jack if you are using an external power adapter).
- When the deskphone displays the 'Step 2' during the boot, repeatedly press the '*' and '#' keys in succession until a menu is displayed.
- **VPN** (Scroll down the menu).
 - **VPN Config**
 - Enter the new PIN Code.
 - Validate.
 - **Enable VPN:** you have to activate this option to use your deskphone for teleworking.
 - **Server:** enter the address of the VPN server.
 - **PSK:** enter the pre-shared key to establish a secure connection with the VPN server. The PSK can be unique for all remote workers on a same installation or can be specific to each remote worker. In the first case, the VPN authentication has to be enabled.
 - **VPN Tftp** › **Use TFTP servers, tftp1, tftp2,port:** if the TFTP servers are required, activate this option and enter the addresses and port of the TFTP servers.
 - **VPN Auth** › **Use Authentication, User, Pass:** activate this option if a logon to the VPN server (username and password) is required. The VPN authentication can be disabled in case a specific PSK is used for each remote worker.
 - **VPN Pincod** › **Request Pin on Boot:** if this option is activated, the PIN code is required when you boot your deskphone. We recommend you activate this option.

-  Select this icon to return to the main menu.
- Select this icon to save parameters.
- The VPN configuration is saved and the main menu is displayed.
-  select this icon to exit the configuration menu. The deskphone restarts.
- Enter the PIN code if you have selected the option (*Request Pin on Boot*).
- Validate.
- Your deskphone is ready for teleworking.

If you leave the PIN code request menu when the phone is starting, the phone will start without VPN activated.

7.30.2 Change the configuration

You have to change a parameter of the VPN configuration.

- Restart the deskphone (unplug and plug in the power jack if you are using an external power adapter or the Ethernet connector – LAN).
- When the deskphone displays the 'Step 2' during the boot, repeatedly press the '*' and '#' keys in succession until a menu is displayed.
- *VPN* (Scroll down the menu).
- Select a submenu to change the configuration (*VPN Config, VPN Tftp, VPN Auth, VPN Pincod*).
- Enter your PIN code (if an administrator password is defined by the system, you can use it to access to the VPN configuration by selecting: *Use Password*).
- Validate.
- Change parameters.
- Select this icon to save parameters.
- The VPN configuration is saved and the main menu is displayed.
-  select this icon to exit the configuration menu. The deskphone restarts.
- Enter the PIN code if you have selected the option (*Request Pin on Boot*).
- Validate.
- Your deskphone is ready for teleworking.

7.30.3 PIN code

The PIN code is composed of 4 digits. You can access the VPN configuration by entering the PIN code or the administrator password if defined by the system. Depending on the VPN configuration, the PIN code is requested when you boot your deskphone. We recommend you enable this option for security reasons and if you need your phone in remote and in business place (See Reconnect your deskphone in your business place).



If the PIN code is incorrect 5 times in succession, the PIN code and VPN parameters will be erased. If no administrator password is defined by the system, the PIN code is required to access VPN configuration.

7.30.4 Reset your PIN code

- Restart the deskphone (unplug and plug in the power jack if you are using an external power adapter or the Ethernet connector – LAN).
- When the deskphone displays the 'Step 2' during the boot, repeatedly press the '*' and '#' keys in succession until a menu is displayed.
- **VPN** (Scroll down the menu).
- **VPN Pincod**
- Enter your PIN code.
- Validate.
- **Set new Pincode**: enter the new PIN Code.
- Select this icon to save parameters.
- The VPN configuration is saved and the main menu is displayed.
-  select this icon to exit the configuration menu. The deskphone restarts.
- Enter the PIN code if you have selected the option (**Request Pin on Boot**).

7.30.5 Reconnect your deskphone in your business place

You phone is already configured for teleworking.

- Connect your deskphone to the network (and plug in the power jack if you are using an external power adapter).
- If the option to enter PIN code when you boot your deskphone is enabled in the VPN configuration (**Request Pin on Boot**):
 - The PIN code is requested.
 -  Select this icon to go back.
 - The phone restarts in normal mode. The VPN is temporary disabled until the next reboot.
- If the option is not enabled:
 - When the deskphone displays the 'Step 2' during the boot, repeatedly press the '*' and '#' keys in succession until a menu is displayed.
 - **VPN** > **VPN Config**
 - Enter your PIN code.
 - Validate.
 - **Enable VPN**: Disable the teleworker.
 - Select this icon to save parameters.
 - The VPN configuration is saved and the main menu is displayed.
 -  select this icon to exit the configuration menu.
 - The phone restarts in normal mode.

7.30.6 Reconnect your deskphone in remote place

Your phone is already configured for teleworking but it was connected in your place of business. You need to reconnect it in a remote place.

- Connect your deskphone to the network (and plug in the power jack if you are using an external power adapter).
- If the option to enter PIN code when you boot your deskphone is enabled in the VPN configuration (**Request Pin on Boot**):
 - The PIN code is requested.
 - Enter PIN code.
 - Validate.
 - The phone starts as teleworker.

- If the option is not enabled (*Request Pin on Boot*).
 - When the deskphone displays the 'Step 2' during the boot, repeatedly press the '*' and '#' keys in succession until a menu is displayed.
 - *VPN* > *VPN Config*
 - Enter your PIN code.
 - Validate.
 - *Enable VPN*: Enable the teleworker.
 - Select this icon to save parameters.
 - The VPN configuration is saved and the main menu is displayed.
 -  select this icon to exit the configuration menu.
 - The phone starts as teleworker.

7.31 Contacting your administrator (Technical support)

If necessary you may need to contact your administrator.

Before contacting your administrator, make sure you have information such as your phone's codes and software version to hand.

7.31.1 Date code (left) / Technical code (right)

The codes are located under the backshell of the phone. This label is an example and does not represent the one placed on your phone.

1	Date code (left)
2	Technical code (right)

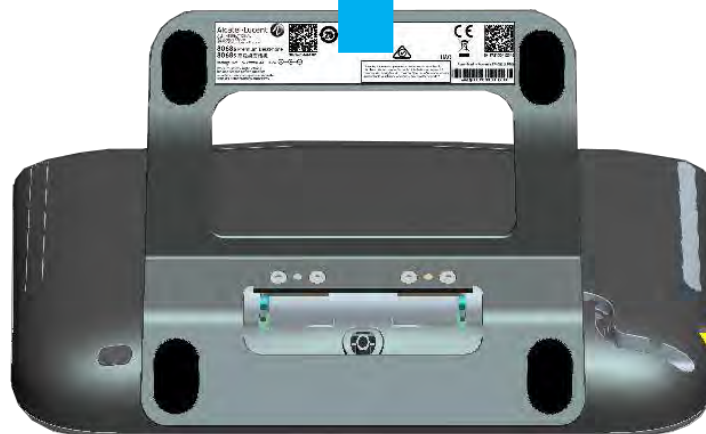

7.31.2 Software version

The software version can be viewed on the phone by following this path:

- Reach the 'Menu' page.
- *Settings* › *Options* › *Version*

7.32 Phone auto test

The auto test of the phone is a quick hardware test of the sound, the display and the LEDs. It lets the user do the first tests directly from the desktop.

- The phone is switched on and connected.
- Reach the 'Menu' page.
- *Settings* › *Options* › *Phone test*
- Auto test has started.
-  To stop the auto test.

8 'Meet me' conference

The 'Meet me' function is used to set up a conference with a maximum of 29 persons (maximum value is configured in OXE system, it can be 7, 15 or 29).

8.1 Initiate a 'Meet me' conference

In order for the participants to join the conference, you must first decide on a meeting time for the conference and send them the access code.

- Enter the 'Meet me' conference prefix. It is defined by the administrator during system configuration. If necessary you may need to contact your administrator.
- Enter the conference access code.

The conference is set-up. Participants must enter this access code to join the conference call. Send the conference call access code to the participants.

In case of network connected OXE systems, to initiate a 'Meet me' conference with a distant OXE system, you have to enter a phone number of distant OXE system after prefix, to locate the conference. For more information, contact your administrator.

8.2 Join a 'Meet me' conference

Once set-up by the conference initiator, other participants can join the 'Meet me' conference.

- Enter the joining code for the 'Meet me' conference. This code is defined by the administrator during system configuration. If necessary you may need to contact your administrator.
- Enter the conference access code.
Conference access code: 'x' digits code defined by the conference master and communicated to the participants so that they can join the conference.
- You are in conference mode.

An audible beep sounds when a participant joins the conference.

You cannot join a conference if there are already the maximum number of participants.

If you cannot directly reach the conference, you have to call first an internal user or an automatic operator. This one dials the call number for joining the 'Meet-me' conference and then transfers your call (10 seconds).

9 ACD: Agent set/ Supervisor station

	8078s BT	8078s	8068s BT	8068s	8058s	8028s	8018
This feature is supported by the following deskphones	●	●	●	●			

9.1 Agent set

A call center solution allows optimum distribution of calls to agents according to their availability and skills.

9.2 Open an agent session (LogOn) – Agent set

- Reach the 'Menu' page.
- *LogOn*
- Enter the identifier number.
- Enter your personal password.

9.2.1 For a decision maker agent

- Use one of the following:
 - Enter the processing group number.
 - *List* >> Select the processing group from a list.

9.3 ACD application welcome screen – Agent set

Once the ACD session is open, the agent can access the ACD application dedicated functions.

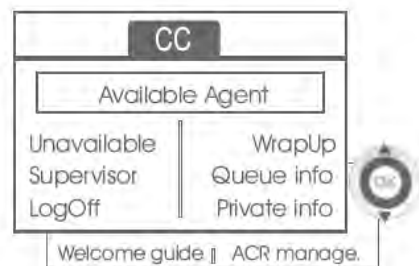

- *Unavailable*
This function allows the agent to be 'logged out' from the ACD application. The 'logged out' function is activated - by default, on opening an agent session (system configuration), by the supervisor or by the agent himself. The agent changes this 'logged out' status by pressing the display key associated with this function.
- *Wrap Up*
After each ACD call, the agent automatically assumes Wrap-up mode. During this mode, the agent does not receive any ACD calls and can carry out the tasks associated with a call. This mode can be terminated at any time by pressing the display key associated with the Wrap-Up function or by waiting for the end of the timer (system configuration).
- *Supervisor*
When the agent is on a break, waiting for a call or in Wrap-up mode, he calls his supervisor directly by pressing this key.
- *Queue info*
By pressing this key, the agent accesses information regarding the queue (number of calls waiting, average or maximum waiting time, number of free, busy or logged out agents).
- *Private info*
Pressing this key informs the agent about the configuration of his set (forwarding status, presence of new messages, associated set, name and number of the set, etc.).

- *Welcome guide*
This key allows the agent to configure the welcome messages, recording, activation/deactivation, loading or playback of a welcome message.
Access to welcome message configuration involves entering the agent identifier number and a password.
- *ACR manage.*
The agent can act on the distribution of the ACD calls by assigning or not assigning expertise areas. Expertise areas can be assigned or deleted one by one or globally.
- *Help*
During a communication, the agent can send an assistance request to the supervisors.
This request can be accepted by a supervisor or rejected if the supervisors are absent, not available or reject the request.

9.4 Close an agent session (LogOff)

- *LogOff*
- Enter your personal password.
- *Apply* >> The session is closed.

9.5 Supervisor station

The supervisor is an agent who has been assigned additional rights. In particular, he can assist the agents, supervise agent activity, intrude or listen-in discretely on a call.

A supervisor can also perform the agent function from the same set.

9.6 Open a supervisor session (LogOn)

- Reach the 'Menu' page.
- *LogOn*
- Enter the identifier number.
- Enter your personal password.

CC	
1300	
Entry	Queue info
LogOff	Private info
Welcome guide	ACR manage.

9.7 Processing group- Supervisor entry/withdrawal

- *Entry*
- Use one of the following:
 - Enter the processing group number.
 - *List* >> Select the processing group from a list.

9.8 Supervision or acceptance of an assistance request

The supervisor has access to the supervision functions either by accepting an assistance request from an agent or by pressing the 'Help ' function key in the 'Perso ' page.

ACD Listening	
Agent number :	
Listen	Intrusion
Restrictive	Permanent
Cancel	

- **Listen**
By pressing this key, the supervisor starts a discrete listen-in procedure. The supervisor can then listen in on the conversation between an agent and his caller, but cannot participate in the conversation.
- **Intrusion**
This key allows the supervisor to intrude in a communication. This intrusion is signalled to the agent and his caller by an audible beep and the supervisor can cut-in on the conversation at any time. If the agent on-hooks or if the supervisor presses the 'Help ' key, only the supervisor and the caller will be in communication.
- **Restrictive**
The agent is in communication with a caller. This function allows the supervisor to talk just with the agent without the caller being informed of this intrusion (restrictive).
- **Permanent**
The supervisor can view on his display the dynamic states (out of service, ACD calls, private calls, Wrap-up, pause, etc.) and static states (withdrawn, available, Log-Off, etc.) of an agent in real-time.
- **Cancel**
Pressing this key results in the rejection of an agent assistance request.

9.9 Close a supervisor session

- **LogOff**
- Enter your personal password.
- **Apply >>** The session is closed.

10 Use the telephone in SIP survivability ('safe' mode)

	8078s BT	8078s	8068s BT	8068s	8058s	8028s	8018
This feature is supported by the following deskphones			●	●	●	●	●

Your telephone is compliant with the SIP standard and can be used in simplified mode in a SIP environment.

According to the configuration the telephone system of your company, your phone set can automatically switch to 'safe' mode in case of loss of connection with the system, in order to ensure continuity of service. Then, your telephone is running in SIP mode until the connection with the telephone system of your company is re-established.

In SIP mode, each telephone is identified by a character string called the URI. Within your company, the URI of your contact is usually the contact's telephone number.

For more information, contact your installer or administrator.



Pre-programmed function keys are disabled in SIP mode.

123<>abc: If your set is not provided with a magnetic keyboard, use the alpha-numeric keyboard to enter letters. Use the alpha-numeric keyboard key to switch between the numeric and alphabetic keyboard. When in alphabetic mode, the LED corresponding to the key remains lit up.

10.1 Making a call

10.1.1 Take the line

Use one of the following:

- Unhook the handset › Enter the destination number.
-  Hands-free › Dial the destination number.
-  Line key › Dial the destination number.



›› You hear a tone.

10.1.2 Call by dialing internal number of your contact

Use one of the following:

- Dial directly the number for your call.
- Take the line › Dial the destination number › *Call*

10.1.3 Call using your contact's URI

- Take the line.
- *Dial by URI*
- 
- Enter your contact's URI.
-  / *Call*

In SIP mode, each telephone is identified by a character string called the URI. Within your company, the URI of your contact is usually the contact's telephone number.

10.2 Make a call using the personal phone book

- Use one of the following:
 - *Directory*
 - Take the line **>** *From directory*
- Select your contact from the list.
- *Call*

10.3 Redialing the last number dialed

-  Redial key (short press) **>>** Last number redial.

10.4 Receiving a call

10.4.1 Stop the ringer

Use one of the following:

-  Press this key once.
- *Silence*



10.4.2 Reject the call displayed

Use one of the following:



-  Press this key twice.
- *Reject call*

10.4.3 Answer the call

Use one of the following:



- Unhook the handset.
-  Hands-free.
- *Take call*
-  Select the 'incoming call' icon.
-  Line key.

10.5 Making a second call during a conversation

- During a conversation.
- Use one of the following:
 - *New call* **>>** The first call is on hold.
 -  Free line key.
- Use one of the following:
 - Number of second contact.
 - *Dial by URI* **>>** Call using your contact's URI.
 - *From directory* **>>** Call from your personal directory.
 -  Redialing the last number dialed.



In SIP mode, each telephone is identified by a character string called the URI. Within your company, the URI of your contact is usually the contact's telephone number.

10.5.1 To cancel your second call and recover the first



- You are in conversation with the second contact and the first one is on hold.
- Use one of the following:
 - *Enquiry off*
 -  Hang up
- Use one of the following:
 -  Line key with light flashing
 - *Retrieve*

» You are on the line with your first contact

10.6 Answering a second call during a conversation

- During a conversation, another person is trying to call you » Name or no. of the caller displayed for 3 seconds.
- Use one of the following methods to answer the displayed call.
 -  Line key for which icon is flashing.
 -  Line key with light flashing.
 - *Take call*
- The first call is on hold.

To return to your first contact and end the conversation in progress

- Use one of the following:
 - *Enquiry off*
 -  Hang up.
- Use one of the following:
 -  Line key with light flashing.
 - *Retrieve*



» You are on the line with your first contact

10.7 Placing a call on hold (hold)

During a conversation, you wish to place the call on hold and recover it later, on the same telephone.

- During a conversation.
- *Put on hold* » Your call is placed on hold .

Recover the call on hold:

- Use one of the following:
 -  Line key with light flashing.
 - *Retrieve*
 -  Line key for which icon is flashing.

10.8 Switching between calls (Broker call)



During a conversation, a second call is on hold.

- Select the contact on hold >> You are in conversation with the second contact and the first one is on hold.

10.9 Transferring a call

- You are in communication with a first caller.
 - Calling a second person during a conversation >> The first call is on hold.
 - *Transfer to* >> The two callers are connected.
- You are in communication with two callers.
 - *Transfer* >> The two callers are connected.
- You are in communication with a first caller. A second caller is on hold. You want to transfer the ongoing call to a 3rd caller.
 - *Transfer to 3rd*
 - Call the recipient of the transfer.
 - *Transfer to* >> The two callers are connected.

Recover the call on hold:

- Use one of the following:
 -  Line key with light flashing.
 - *Retrieve*
 -  Line key for which icon is flashing.

10.10 Three-way conference with internal and/or external contacts (conference)

- During a conversation, a second call is on hold.
- *Conference* >> You are in conference mode.

10.10.1 Hang up on all participants (If conference is active)



- Use one of the following:
 -  Hang up.
 - *End of conference*

10.10.2 After the conference, to leave your two contacts talking together:

- *Transfer*
-  Hang up.

10.11 Mute, so that your contact cannot hear you

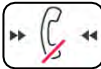
You can hear your contact but he/she cannot hear you:

- During a conversation.
-  Disable microphone >> The key lights up .
-  Resume the conversation >> The key is no longer lit .

10.12 Adjust audio volume

To adjust the volume level of the loudspeaker, handset or headset during a call:

-   Adjust audio volume.

10.13 Forwarding calls to another number (immediate forward)

The number can be your home, mobile, voice mailbox or an internal extension (operator, etc.).

- *Forward* >> Display the forwarding status of your set.
- *Immediate fwd*
- Call the recipient of the forwarding.
- *Save* >> Validate the forwarding.
- 

You can make calls, but only the destination number can call you.

10.13.1 Modify the forwarding

- *Forward* >> Display the forwarding status of your set.
- *Immediate fwd*
- Call the recipient of the forwarding.
- *Save* >> Validate the forwarding.
- 





10.13.2 Cancel the forwarding

- *Forward* >> Display the forwarding status of your set.
- *Deactivate*
- 







10.14 Adjusting the audio functions

- Reach the 'Menu' page.
- *Settings* > *Phone* > *Ringing*





10.14.1 Choose the tune

- *Melody*
- Select the melody of your choice (16 tunes).
- 
-  >> End.
-  /  >> To adjust other audio features.





10.14.2 Adjusting the ringer volume

- *Level*
-   Select the volume you want: (12 levels).
- 
-  >> End.
-  /  >> To adjust other audio features.



10.14.3 Activate/deactivate silent mode / Activate/deactivate meeting mode (progressive ringing)

- *More options*
 - *Normal ringing*
 - *Silent mode*
- *Progressive ringing*
- 
-  >> End.
-  /  >> To adjust other audio features

10.14.4 Activate/deactivate discreet ring mode

- *Beep*
- *One beep before ringing*
- *Three beeps before ringing*
- *Ring without beep*
- 
-  End.
-  /  To adjust other audio features.

10.14.5 Adjust ringer volume while a call arrives

- Your telephone rings.
-   Adjusting the ringer volume.

10.15 Selecting language

- Reach the 'Menu' page.
- *Settings* > *Phone* > *Language*
- Select the language of your choice.
- 

10.16 Sending DTMF signals

During a conversation you sometimes have to send DTMF signals, such as with a voice server, an automated attendant or a remotely consulted answering machine.

By default during a communication, your telephone in SIP mode is configured to send codes in voice frequency: enter these codes directly using the keys on your telephone.

For more information regarding this configuration, contact the person in charge of your installation.

11 Accessories

The ALE-supported accessories are intended to work smoothly on most/all of our clients (hardphones, softphones). The list of accessories presented in this document is not contractually binding and may be modified without prior warning.

11.1 List of accessories

11.1.1 Jack 3.5 mm 4-pole corded headset

- Corded Monaural Wideband Headset (Plantronics HW510N 3GV28047AD).
- Corded Binaural Wideband Headset (Plantronics HW520N 3GV28048AD).
- Quick Disconnect to Jack 4 poles, pack of 10 items (Plantronics, 3GV28177AB).
- Corded Premium Monaural Wideband Headset (Sennheiser SC 232 3GV28047BA).
- Corded Premium Binaural Wideband Headset (Sennheiser SC 262 3GV28048BA).
- Jack Monaural Headset (Plantronics C215 3BN78155AA).
- Easy Disconnect to Jack 4 poles x10 (Sennheiser CMB 01 CNTRL 3GV28181BA).
- Quick Disconnect to jack 4 poles x10 (Plantronics 3GV28177AB).



11.1.2 USB headset

- USB Binaural Headset (Plantronics C325-1 3GV28057AB).

11.1.3 Bluetooth® headset

- Bluetooth Monaural Headset (Plantronics Voyager Legend 3BN67215WW).

11.1.4 Conference module

- Alcatel-Lucent 8125 Audiooffice usb.
- Alcatel-Lucent 8115 Audiooffice usb.

11.1.5 EHS interface

- External ringing interface module (MWS 3GV28050AA).
- USB external ringing interface module (coming soon)

11.28115/8125 Audiooffice



	8078s BT	8078s	8068s BT	8068s	8058s	8028s	8018
The accessory is supported by the followinf sets	●	●	●	●	●	●	●

This section describes how to use the conference module 8115/8125 Audiooffice with your deskphone. For more information about 8115/8125 Audiooffice see the user manual of the device.

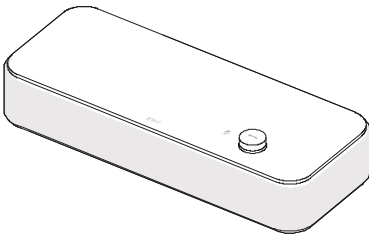
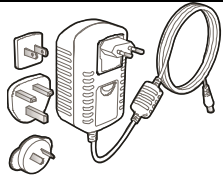
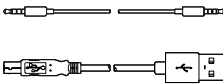
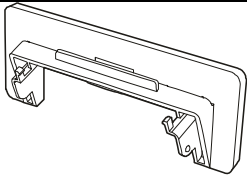
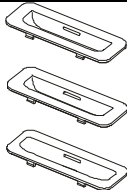
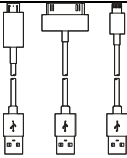
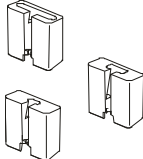
11.2.1 Box content

		8115 Audiooffice	8125 Audiooffice
Alcatel-Lucent 8115 Audiooffice base		●	
Alcatel-Lucent 8125 Audiooffice base			●
AC adapter		●	●
Jack 3.5 mm cable USB type A - type B cable		●	●
Tablet holder			●
Lightening, 30 pin and micro-USB adapters			●
Lightening, 30 pin and micro-USB cables			●
Lightening, 30 pin and micro-USB cable adapters			●

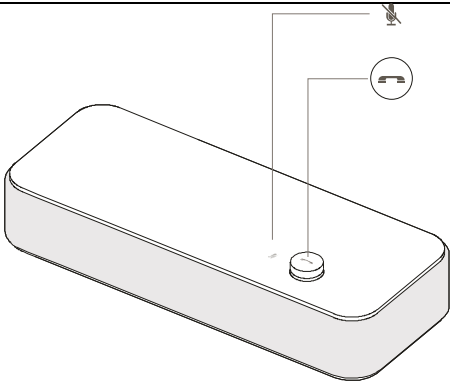
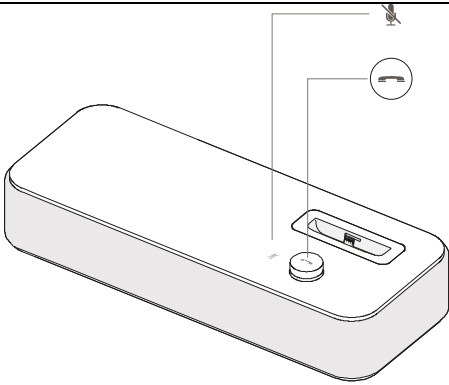
11.2.2 Description

8115 Audiooffice		8125 Audiooffice	
			
	Mute	Mute	
	Adjust volume. Receive and End a call.	Adjust volume. Receive and End a call. Bluetooth pairing.	

11.2.3 Set-up

Once installed, to benefit from the best sound quality avoid placing any objects (walls or cumbersome objects) within a range of 20cm.

1. Plug the mains power adapter into the back of the base and into a wall mount socket.

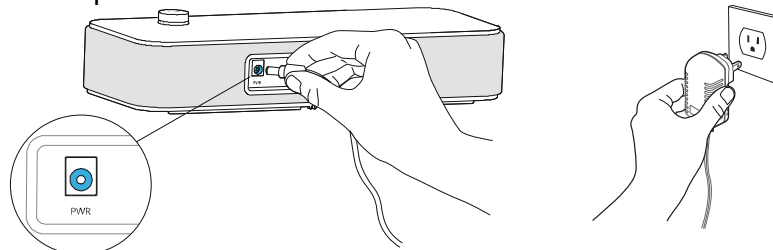

2. Press the On / Off button at the back of the base.

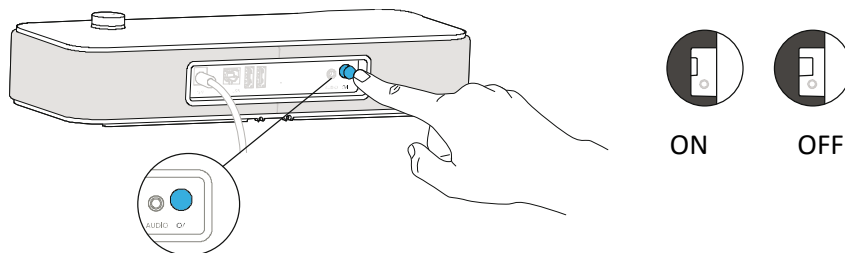

11.2.4 Connect your devices

8078s/8068s Bluetooth® Premium Deskphone

Connect the conference module 8125 Audiooffice to your deskphone via Bluetooth connection (see corresponding chapter of your deskphone and the conference module).

8078s Bluetooth®/8068s Bluetooth®/8078s/8068s/8058s/8028s Premium Deskphone

Use the provided jack cable to connect your deskphone to the conference module.

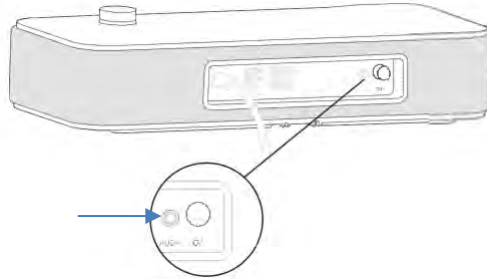

8018 DeskPhone

The USB slave port is to connect your deskphone to have the sound on the 8115/8125.

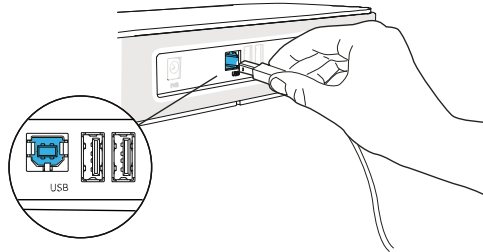

Other Devices

The 8115/8125 Audiooffice can be used to connect other device, like mobile phone (via Bluetooth, USB or Jack) or computer (Bluetooth, Jack, USB).

11.2.5 Bluetooth®(8125 Audiooffice)

The voice messages are in English until a first device is paired, the unit will then adopt the language of the Bluetooth device paired.

Long push the volume button until you hear a sound signal. A 'Pairing mode: waiting for connection' message allows you to pair your Alcatel-Lucent 8125 Audiooffice in your device Bluetooth menu. A final sound confirms the pairing.

Disconnect a paired device

Long push the volume button until hearing a double-sound signal. The last connected device is then disconnected and auto-connection is stopped. A 'Disconnecting' message and a sound signal confirm the disconnection.

Unpair all the connected devices

Long push the volume button until hearing a three-sound signal. A 'Clearing all subscriptions' message confirms it.

11.2.6 Use your device

Use the 8115/8125 Audiooffice as a conference module.

Placing or receiving an Alcatel-Lucent Deskphone call in jack mode

Upon jack connection to the Alcatel-Lucent Deskphone, user needs to configure the jack interface to 'External Handsfree' in order to use it for conference.

The jack connected, dial from your Alcatel-Lucent Deskphone and press the Alcatel-Lucent 8125 Audiooffice volume button to use it as a conference device.

To end the call, hang up the call from the phone.

Muting a call can be done with the Audiooffice Mute button or through the Alcatel-Lucent Deskphone Mute key.

Placing or receiving an Alcatel-Lucent Deskphone call in Bluetooth mode (8125 Audiooffice)

Add the Alcatel-Lucent 8125 Audiooffice in the Alcatel-Lucent Deskphone Bluetooth device list with entering 0000 as a pin code.

Dial from your Alcatel-Lucent Deskphone and press the Alcatel-Lucent 8125 Audiooffice volume button to use it as a conference device.

To end the call, you can press the volume button again or hang up the call from the phone.

Muting a call can be done with the Audiooffice Mute button or through the Alcatel-Lucent Deskphone Mute key.

Adjusting the volume

Turn the volume button to regulate the volume coming from the speakers.

Activating and deactivating the mute

Tap the Mute icon from your Alcatel-Lucent deskphone or directly from the Alcatel-Lucent 8125 Audiooffice icon.

Activating and deactivating the speakers

To accept a call in speaker mode or to switch to speaker mode during a call, press the volume button on the base.

11.2.7 Use the 8125 Audiooffice with your mobile

You can connect your mobile to the conference module by using the Lightning, 30 pin and micro-USB adapters. A Bluetooth® connection is needed to place and receive your mobile calls on the Alcatel-Lucent 8125 Audiooffice. To receive and end a voip call, use your Alcatel Lucent softphone application.

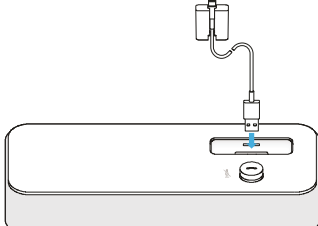
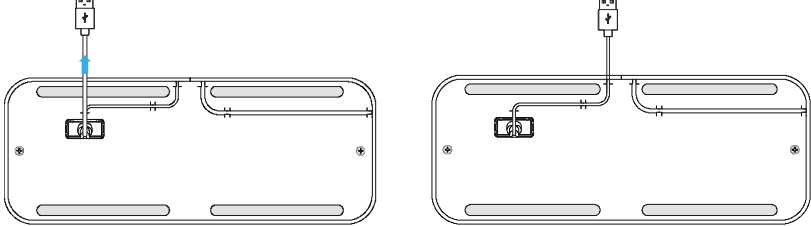
<p>Insert the cable suitable to your smartphone into the matching cable adapter. Place the cable in the cable hole.</p>	
<p>Slide the cord into place through the interstices under the base.</p>	
<p>Slide the cord into place through the interstices under the base.</p>	

Plug the USB connector to the left USB port at the rear of the device.

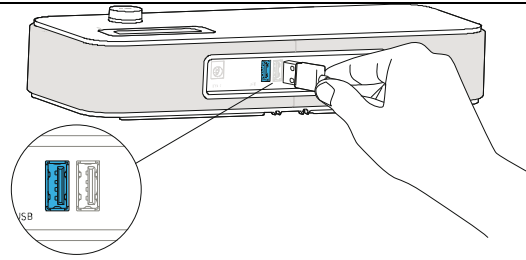

Insert the suitable adapter to your smartphone, or none if you use a case and your device doesn't fit.

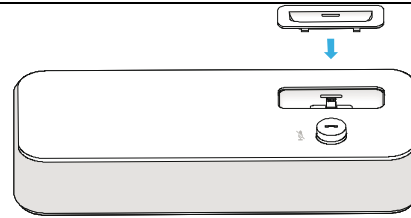



11.3 External ringing interface module (MWS 3GV28050AA)

	8078s BT	8078s	8068s BT	8068s	8058s	8028s	8018
The accessory is supported by the following sets	●	●	●	●	●	●	

You have to use a RJ11 to SATA adapter to connect your deskphone to this device. The RJ11 to SATA adaptor is sold separately.

The external ringing interface module allows driving an external system (like a ring or a lamp), following the ring tone cadence of the phone set connected on the telephone line. A switch on the electronic board allows selecting between 2 operation modes.

-  Follows the cadence: the relay follows exactly the ring signal.
-  Hold mode: the relay is held for 0,7 s after the ring signal is gone. It erases some of the ring pulses.

11.3.1 List of supplies

- 1 external ringing interface module.
- 3 circuits plug to screw.
- 1 RJ11/RJ11 3 meters (10 feet) cable.
- 1 DC Japan/DC Japan 3 meters (10 feet) power cable.

A power supply may be required to power the module when used with IP phone powered remotely (Power Over Ethernet).

Use only the following power supply (Sold separately):

- 3AK27097 (commercial part number).
- 1AF00446 (technical part number).



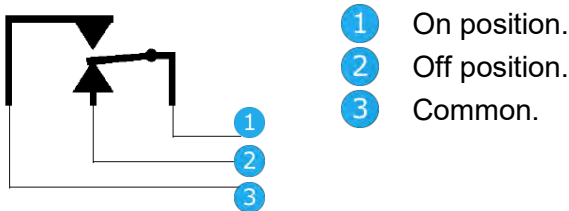

11.3.2 Installation

WARNING: The module must be closed before use. No settings require the module to be open.



11.3.3 Connect the device



Phone set connected over IP and to an external power supply		
1	Connected to the DC power jack of the deskphone by using DC Japan cable.	
2	Connected to the power supply of the device.	
3	Connected to the SATA connector of the deskphone, by using the RJ11 cable with an adpatator RJ11 to SATA. The RJ11 to SATA adaptator is sold separately.	 SATA
Phone set connected over IP and PoE		
1	Connected to the DC power jack of the deskphone by using DC Japan cable.	
2	Connected to the power supply of the device.	
3	Connected to the SATA connector of the deskphone, by using the RJ11 cable with an adpatator RJ11 to SATA. The RJ11 to SATA adaptator is sold separately.	 SATA

11.4 Wall mounting kit

11.4.1 8068s, 8058s, 8028s Premium DeskPhone

1

1. Rotate the metal foot to flat.
2. Remove the rubber cover on phone back shell each side.

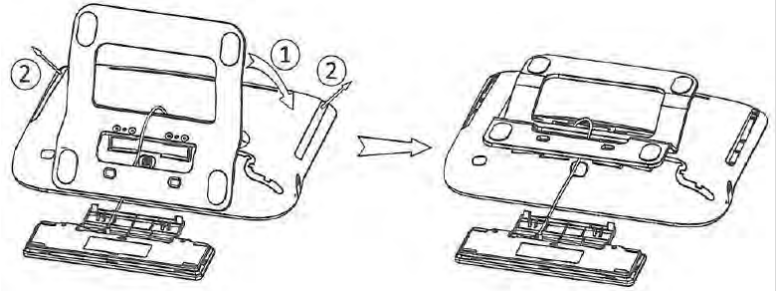

2

1. Drill two holes on the wall (separation=90mm, diameter=6mm).
2. Insert the fastener into the holes on wall (P/N: 1AD007550003).
3. Fix the support with both screws and adjust (P/N: 1 1AD007460003). The support is used as a reference and must be removable.

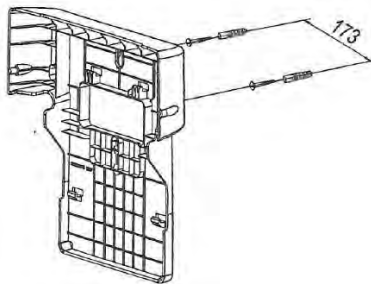

3

1. Put the support on the back side of the phone.
2. Slide it to top side and make sure the 4 hooks hold the metal foot.
3. Attach the mini-keyboard to the metal foot (insert the 2 hooks into the two holes on metal foot).
4. Push on the two corners of mini-keyboard to fix it in the support.

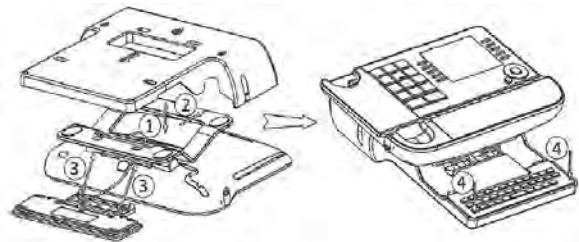

4

1. Fix the support with the phone by 1 screw (P/N: 1AD100020003).
2. Connect cables through the hole on support left side or right side.

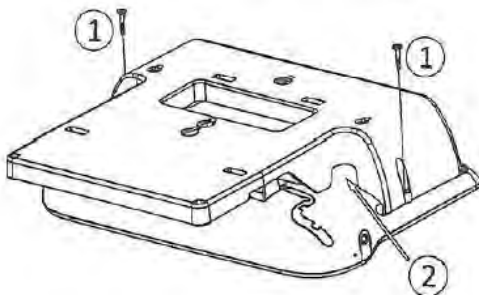

To connect ethernet, use RJ45 cable (P/N: 1AB045210162).

To connect the power, use extension cable (P/N: 1AB203010001).

5

1. Hang the assembled phone with support on the wall.

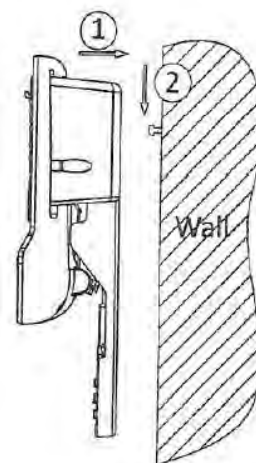

11.4.2 8018 DeskPhone

1

4. Drill two holes on the wall (separation=90mm, diameter=6mm).
5. Insert the fastener into the holes on wall (P/N: 1AD007550003).
6. Fix the support with both screws and adjust (P/N: 1 1AD007460003). The support is used as a reference and must be removable.

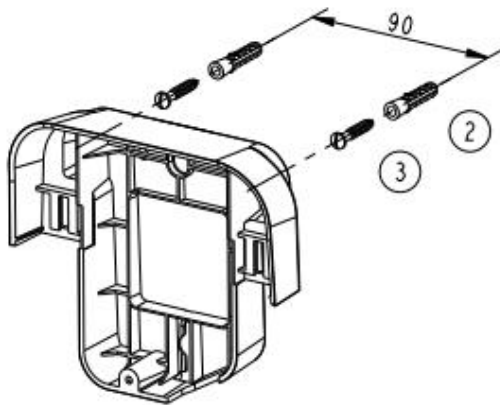

2

5. Put the support on the back side of the phone.
6. Slide it from top side and make sure the 2 snaps are engaged on the shell.

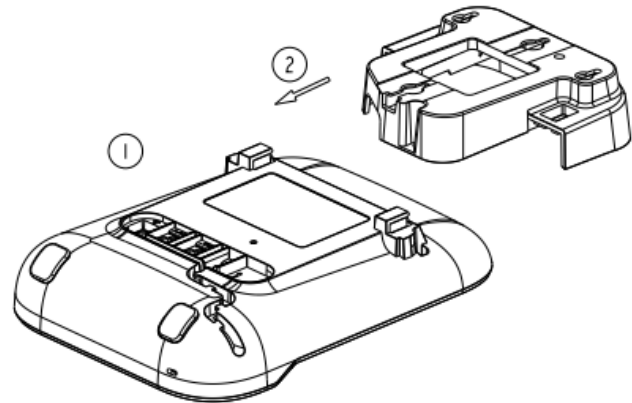

3

3. Fix the support with the phone by 1 screw (P/N: 1AD204430001).
4. Connect cables through the hole on support bottom side.

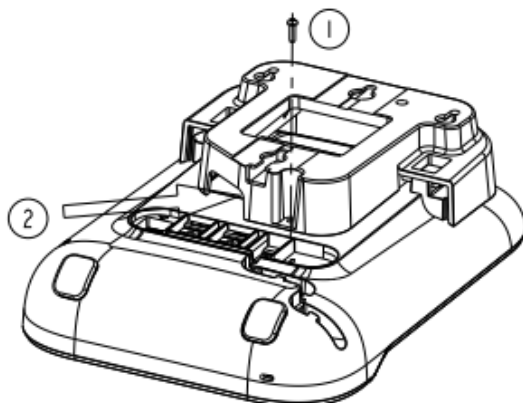

4

2. To connect ethernet, use RJ45 cable (P/N: 1AB045210162).

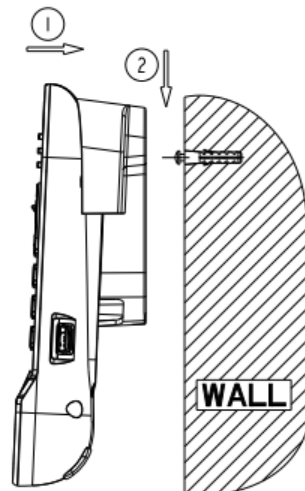

11.5 Connect a 3 pole jack headset

Your phone is equipped with a 3.5 mm, 4 pole jack. If your headset is not compatible (3 pole jack), you have to use adapters. Contact the manufacturer of your headset to find the appropriate adapter.

1	A 3 pole to 4 pole jack adapter to connect the jack of the headset to the DeskPhone to manage audio
2	RJ11 to SATA adapter to connect the RJ11 connector of the headset to the SATA connector to the DeskPhone to manage ringing
3	EHS adapter (depends on your headset)

Example 1:

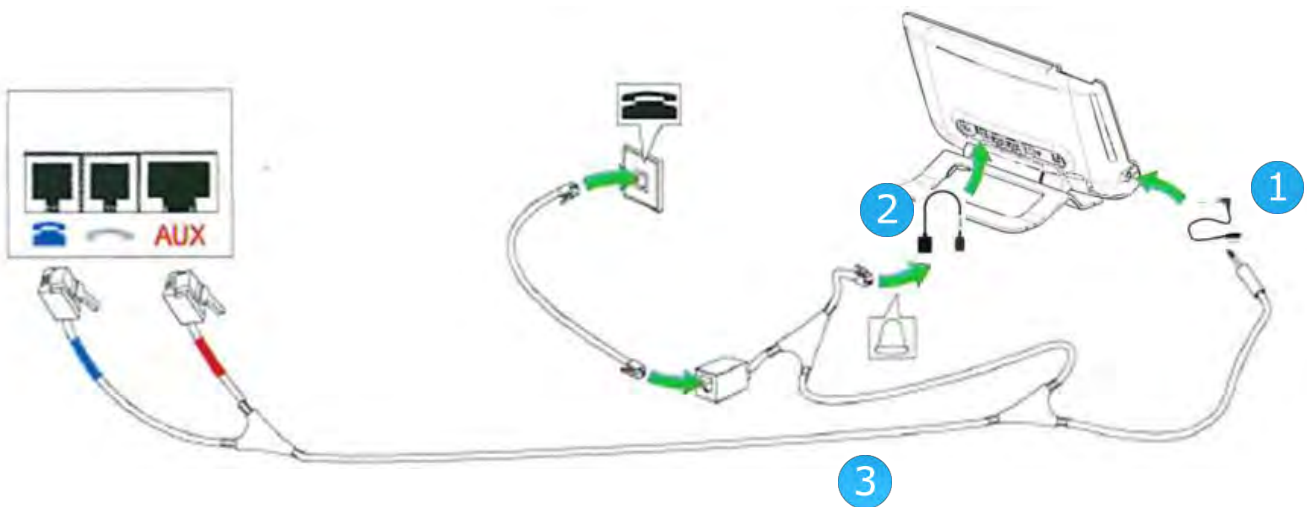

Example 2:

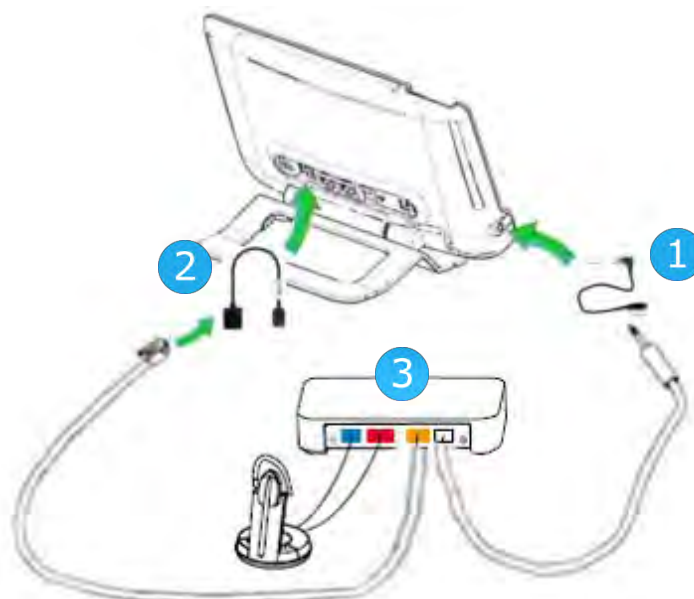

12 Technical specifications

	8078s BT	8078s	8068s BT	8068s	8058s
Width	252 mm (9,92 in)	252 mm (9,92 in)	252 mm (9,92 in)	252 mm (9,92 in)	252 mm (9,92 in)
Depth on a table	200 mm (7,87 in)	200 mm (7,87 in)	200 mm (7,87 in)	200 mm (7,87 in)	200 mm (7,87 in)
Depth with wall mounting kit, and handset					
Height	204 mm (8,03 in)	204 mm (8,03 in)	204 mm (8,03 in)	204 mm (8,03 in)	204 mm (8,03 in)
Weight	1450 g	1450 g	1350 g	1350 g	1350 g
Adjustable foot stand range	25° - 60°	25° - 60°	25° - 60°	25° - 60°	25° - 60°
Color	Moon grey	Moon grey	Moon grey	Moon grey	Moon grey
Display	5 inch capacitive touch color, 480 x 800 pixels, effective display area size 108.00 x 64.80 mm	5 inch capacitive touch color, 480 x 800 pixels, effective display area size 108.00 x 64.80 mm	3.5 inch color, 240 x 320 pixels, effective display area size 70.08 x 52.56 mm	3.5 inch color, 240 x 320 pixels, effective display area size 70.08 x 52.56 mm	3.5 inch color, 240 x 320 pixels, effective display area size 70.08 x 52.56 mm
Power over Ethernet (IEEE 802.3af)	Class 2	Class 2	Class 2	Class 2	Class 2
Power consumption (PoE) Idle – Active(w/o Add-on, w/o USB)	2.1 W – 3.5 W	1.9 W – 3.2 W	2 W - 3.1W	1.8 W - 2.8 W	1.6 W – 2.2 W
Operating conditions	-5°C - +45°C (23°F - 113°F)	-5°C - +45°C (23°F - 113°F)	-5°C - +45°C (23°F - 113°F)	-5°C - +45°C (23°F - 113°F)	-5°C - +45°C (23°F - 113°F)

	8028s	8018
Width	252 mm	164 mm (6.46 in)
Depth on a table	200 mm (7,87 in)	200 mm (7.87 in)
Depth with wall mounting kit, and handset		100 mm (3.94 in)
Height	204 mm (8,03 in)	170 mm (6.69 in)
Weight	1350 g	675 g (1.48 lbs)
Adjustable foot stand range	25° - 60°	45°
Color	Moon grey	Black
Display	2.8 inch, 64 x 128 pixels black & white, white backlight, effective display area size 64 x 32 mm	2.4 inches 128 x 64 pixels graphic black/white LCD display, effective display area size 54.8 x 28.5 mm (2.15 x 1.12 in)
Power over Ethernet (IEEE 802.3af)	Class 1	Class 1
Power consumption (PoE) Idle – Active(w/o Add-on, w/o USB)	1.5 W – 2 W	
Operating conditions	-5°C - +45°C (23°F - 113°F)	-5°C - +45°C (23°F - 113°F)

	External ringing interface module (MWS 3GV28050AA)	8115 Audiooffice	8125 Audiooffice
Maximum distance between the phone set and the device	3 m (10 feet)		
Width	124 mm (1,2 in)	290 mm (11,4 in)	290 mm (11,4 in)
Depth on a table	130 mm (5 in)	114 mm (4,5 in)	114 mm (4,5 in)
Height	30 mm (1,2 in)	53 mm (2,1 in)	53 mm (2,1 in)
Weight	170 g	1497g (3,3 lbs)	1497g (3,3 lbs)
Adjustable foot stand range			
Color	Black and silver	Black	Black
Power consumption	500 mW		
Power consumption	2A 220 Vdc 250 Vac	100-240V / 12V 3A AC	100-240V / 12V 3A AC
Power consumption	<ul style="list-style-type: none"> • 30 Vdc / 2 A • 220 Vdc / 0.27 A • 120 Vdc / 0.5 A • 250 Vac / 0.25 A 		
Operating conditions		0°C – 40°C (32 °F - 104 °F)	0°C – 40°C (32 °F - 104 °F)

13 Ordering information

8018 DeskPhone	3MG27201AA
8018 WALL MOUNTING KIT	3MG27210AA
8018 CUSTOMIZABLE CLIP (x10)	3MG27211AA
8018 NOE PAPER LABEL COVER (x10)	3MG27212AA
8018 US NOE PAPER LABEL COVER (x10)	3MG27213AA
8018 PAPER LABEL (x64)	3MG27215AA
8018 PLASTIC FOOT (x10)	3MG27216AA
8018 SIP PAPER LABEL COVER (x10)	3MG27217AA
8028s Premium Deskphone	3MG27202xx
8058s Premium Deskphone	3MG27203xx
8068s Premium Deskphone	3MG27204xx
8078s Premium Deskphone	3MG27205xx
8068s Premium Deskphone BT	3MG27206xx
8078s Premium Deskphone BT	3MG27207xx
8028/8029 paper labels (x50)	3MG27114AA
Premium Add-on 10 keys module	3MG27105AB
Premium Add on 10 key modules paper labels (x64)	3MG27115AA
Premium Smart display 14 keys module with clip	3MG07032WW
Premium Add-on 40 keys module with clip	3MG07033WW
Premium Add on 40 key modules paper labels (x50)	3MG27116AA
Wide Band Comfort Handset	3MG27032AA
Wide Band Bluetooth Handset	3MG27209AA
Magnetic Alphabetic Keyboard	3MG27208xx
Premium Wall Mounting Kit	3MG27110AA
Monaural Headset	3GV28047xx
Binaural Headset	3GV28048xx
Bluetooth Headset	3BN67215WW
Binaural USB Headset	3GV28057xx
AC/DC Power Adapter	3MG27006xx
Conference Module 8115 Audiooffice	3MG08001AA
Conference Module 8125 Audiooffice	3MG08002AA
External ringing interface module without PSU	3GV28050AA

14 Guarantee and clauses

14.1 Safety Instructions

- Changes or modifications to the equipment not expressly approved by the party responsible for compliance could void the user's authority to operate the equipment.
- Magnets could affect the functioning of pacemakers and implanted heart defibrillators. Keep a safe distance between your pacemaker or implant defibrillator and the handset which includes magnetic elements: 4 centimeters (1,6 inches) at least.
- It is recommended to follow the standard acceptance procedures before using this equipment in human safety critical areas (hospitals...).
- The handset includes magnetic elements that may attract sharp metallic objects. To prevent injury, before each use ensure sharp metallic objects are not stuck to the earpiece and microphone.
- Avoid using phones (other than cordless type) during an electrical storm. There may be a remote risk of electric shock from lightning.
- Do not use the device in environments where there is a danger of explosion.
- Do not plug this phone into an Integrated Services Digital Network (ISDN) connection or into a regular Public Switched Telephone Network (PSTN) connection. This can result in severe damage to the phone.
- Never allow your telephone to come into contact with water.
- To clean your telephone, use a soft damp cloth. Never use solvents (trichlorethylene, acetone, etc.) which may damage the plastic parts of your telephone. Do not use aerosol cleaners.
- 8018 DeskPhone - 80x8 / 80x8s Premium DeskPhone - 8088 Smart DeskPhone: this product is intended to be supplied, either via the Ethernet (LAN) port, or via the DC-in by a Certified Direct Plug-In Power Unit approved as 'LPS' (Limited Power Source) against CSA/UL/IEC 60950-1 and rated 48V dc, minimum 0.27A. Allowed power supply is: WA-13B48R – Asian Power Devices Inc.
- A Bluetooth® Handset with integrated battery is available with certain Product variants. The battery must be charged during 6 hours before initial use and must be replaced correctly to prevent danger of explosion. Use only the recommended battery. Contact your Business Partner if you need a spare battery.
To limit the risk of interference, people with pacemakers must keep the wireless telephone away from their equipment (minimum distance of 15 cm/6 inches).
- Some Premium DeskPhones and Smart DeskPhones also offer a Bluetooth® radio interface for Bluetooth® handsets or other Bluetooth® devices frequency range 2402-2480 MHz, radiated power 5 mW.
- If you are connected to a POE connection do not use an external Power Supply.
- The PoE (Power over Ethernet) devices that supply or receive power and their connected cables must all be completely indoors.
- 8078s Premium DeskPhone - 8088 Smart DeskPhone: The cover of the phone screen is made of glass. This glass could break if the phone is dropped or it receives a significant blow. If the glass chips or cracks, stop using the phone and do not touch the broken glass as this could cause injury to you. Glass cracked due to misuse or abuse is not covered under the warranty.

14.2 Regulatory Statements

EUROPE

This equipment complies with the essential requirements of following directives: 2014/53/EU (RED), 2014/30/EU (EMC), 2014/35/EU (LVD), 2009/125/EC (ErP), 2011/65/EU (RoHS).

Declaration of Conformity may be obtained from:

ALE International 32 avenue Kléber – 92700 Colombes, France
ebg_global_supportcenter@al-enterprise.com

USA and Canada

Phones with Bluetooth® comply with Industry Canada's license-exempt RSSs. Operation is subject to the following two conditions: (1) this device may not cause harmful interference, and (2) this device must accept any interference received, including interference that may cause undesired operation. This equipment has been tested and found to comply with the limits for a class B digital device, pursuant to Part 15 of the FCC Rules. These limits are designed to provide reasonable protection against harmful interference in a residential installation. This equipment generates, uses and can radiate radio frequency energy and, if not installed and used in accordance with the instructions, may cause harmful interference to radio communications. However, there is no guarantee that interference will not occur in a particular installation. If this equipment does cause harmful interference to radio or television reception, which can be determined by turning the equipment off and on, the user is encouraged to try correcting the interference by consulting the dealer.

Exposure to Radio Frequency Signals.

This equipment complies with radiation exposure limits set by FCC/IC and the Council of European Union for an uncontrolled environment. This equipment has very low levels of RF energy and is deemed to be compliant without testing of the specific absorption rate (SAR).

User Instructions

Use this product in temperatures between -5°C to +45°C (23°F to 113°F).

This product is intended for use in an indoor environment only. This apparatus is Hearing Aid Compatible (HAC).

Acoustic shock protection

Maximum sound pressure level for handset is compliant with European, US and Australian standards.

Directive 2003/10/EC specifying the risks inherent in noise at work

The ring contributes towards overall daily noise - at its maximum setting, the level is 105 dBA at 60 cm from terminal. To reduce the level, the following is recommended:- reduce the setting (9 levels of 5 dB) - program a progressive ring.

Privacy

Privacy of communications may not be ensured when using the Bluetooth® handset or any additional Bluetooth® device.



Disposal

The equipment must be returned to a collection point for electronic equipment waste disposal. Defective batteries must be returned to a collection point for chemical waste disposal.

Related Documentation

Other languages for these Safety and Regulatory Instructions and User Documentation are available at the following Web site:

<http://enterprise.alcatel-lucent.com?product=All&page=Directory>.

The information presented is subject to change without notice. ALE International assumes no responsibility for inaccuracies contained herein. Copyright© ALE International 2017.

Features keys	
Mute and interphony.	
Hands-free, handset or headset volume. Adjust the brightness (8078s, 8068s, 8058s). Adjust contrast (8028s, 8018).	
Audio services (hands-free, handset or headset).	
<ul style="list-style-type: none"> Programmable keys (F1 and F2 keys): Lit when the function associated with the key is activated. A service or a direct call can be associated to these keys. Pre-programmed function keys are disabled in 'safe' mode. The F1 and F2 keys are line keys. 	
Redial key: to access the 'Redial' feature. For the 8018 DeskPhone, the redial key is associated with the Off-hook key when the phone is in idle state:	
Quick access to user local menu (long press). Used to obtain information on functions of the 'menu' page and to program key of the 'perso' page (short press). Not available on 8018 DeskPhone.	
Messaging key to access various mail services. This key is lit when you have received a new voicemail, text message or callback request.	
Hands-free key To make or answer a call without lifting the handset.	
END key To terminate a call.	
Bluetooth® wireless handset (Compatible Bluetooth® deskphone)	
Off-hook/On-hook.	
Volume/Mute: <ul style="list-style-type: none"> Short successive presses to change the handset volume level (3 levels). Long press to ensure your caller no longer hears you. 	
Welcome screens	
<p>You can access all of your phone's features from these screens. The default display has three pages that you can access by pressing to the page tabs at the top of the screen. The selected page is highlighted.</p> <ul style="list-style-type: none"> Menu page Contains all functions and applications accessible via the keys associated with the words on the screen. Perso page Contains call line keys (allowing supervision of calls) and programmable call keys. Info page Contains information on the telephone and the status of its functions: name, telephone number, number of messages, activation of transfer function, appointment reminder, etc. 	
	Manage your call forwarding by pressing the forward icon. <ul style="list-style-type: none"> Stationary arrow: No forwarding activated. Blinking arrow: Forwarding activated.
Touchscreen navigation	
	Select a page by pressing the corresponding tab on the screen. The selected page is highlighted. Make your selection by pressing the label on the screen.
	Scroll through a list (features, call log, contact, ...) by pressing the up and down arrow on the screen, or the up-down navigator keys.

	Use the 'OK' softkey to validate your choices and options while programming or configuring.
	Use the 'Back/Exit' icon to go back to the previous step.
	Use the 'Setting' icon for quick access to the user local menu.
	Use the 'Bluetooth®' icon to open Bluetooth® settings.

Navigation keys

	<ul style="list-style-type: none"> OK key: Use this key to validate your choices and options while programming or configuring. Left-right navigator: Used to move from one page to another and display information about current calls (call in progress, calls on hold, incoming call). Up-down navigator: Used to scroll through the content of a page.
	<ul style="list-style-type: none"> Use this key to go back to the previous step. Use this key to go back to the homepage (long press).

Status icons/ Call icons

	Headset connected.		Incoming call icon.
	Telephone locked.		Call in progress icon.
	Appointment programmed.		Call holding icon.

Magnetic alphabetic keyboard







Cursor moving keys (left, right, up and down).	
Caps lock: to write text in capital letters.	
Alt key: to access specific and punctuation characters.	
Enter key: to validate edited text.	
Backspace key: to delete one character in an edit box.	









User local menu





- or (long press): Open the user local menu. The user local menu depends on the type of the set. The user local menu lets you:
- Configuring the audio jack of your telephone.
 - Adjusting the brightness of the deskphone.
 - Activate/deactivate the logo on back shell.
 - Installing a Bluetooth® Wireless accessory.
 - Display all paired Bluetooth® devices.
 - Removing a Bluetooth® accessory (headset, handset, etc.).
 - Use your DeskPhone as a Bluetooth® audio accessory.
 - Change the theme (skin) of your phone.

Alpha-numeric keyboard (8018 DeskPhone)

	123<>abc	Switch the keyboard to the alphabetic mode by selecting the associated preprogrammed key. When activated, the LED corresponding to the key remains lit up.
	Enter alphabetic characters.	The number pad keys have letters that you can display by successive presses. The number is the last character in the series. Some special characters can be displayed by successively pressing the key:
	* % \$ / ~ & () [] = *	
	# @ #	
	1 space - _ 1	
	0 + . , ; : / \ ? ! 0	

Call Dial the number directly or dial the number after pressing a line key (an off-hook key phone or Bluetooth® handset, hands-free key).	
Call by name (Company directory) Enter the name, contact's surname/name or initials and follow the on-screen instructions.	
Answer a call Take the handset off the hook, use an off-hook key (phone or Bluetooth® handset), use the hands-free key, or press the incoming call icon.	
Ignore call / End the call.	
Redial Long press to access the list of the last 8 dialed numbers. Short press to call the last dialed number.	
Make a call-back request to a busy number <i>Callback</i>	
Placing a call on hold (hold) <i>Hold</i>	
Sending DTMF signals <i>Send DTMF</i> Send numbers.	
Mute	
Interphony The phone automatically answers the call. Before the line is taken, you hear a succession of specific beeps.	 Long press
Making a second call during a conversation <i>New call</i>	
Answering a second call during a conversation Select the incoming call icon.	

Switching between calls (Broker call) Select the call on hold icon from the conversation screen.	
To cancel your second call and recover the first You automatically recover the first call.	
Transferring a call You are in conversation with one caller. Call a second contact. <i>Transfer.</i>	
Conference Call the first contact. Call the second contact. <i>Conference (Confer).</i>	
Make calls via your programmed call keys Press the desired programmed call key.	Perso
Programming direct call keys Press the 'I' key or <i>Settings > Phone > Key program</i> Select the key to program. Enter the name and number to associate to the key.	Menu 
Modify the programmed key Press the 'I' key or <i>Settings > Phone > Key program</i> Press the programmed key to be modified. Follow the on-screen instructions.	Menu 
Erase a programmed key Press the 'I' key or <i>Settings > Phone > Key program</i> Select the key to be erased. Follow the on-screen instructions.	Menu 
Customizing your voice greeting <i>Voice mail > Perso options</i> You can listen to the greeting, customize the greeting and set the default greeting.	
Consulting your voice mailbox	
Diverting calls to your voice mailbox Select the forward icon. <i>Imm fwd VM</i> Select the type of call forwarding required.	
Cancel forward Select the forward icon. <i>Deactivate > Deactivate forward</i>	

Do not disturb Select the forward icon. <i>DoNotDisturb (DND)</i>	
Send text messages <i>Message</i> <i>SendTxtMsg</i> Enter the destination number. Select the type of message to send (fixed Msg, New Msg,...).	
Read text messages <i>new text message</i> <i>Read msg</i>	
Information about the phone	Info
Lock/unlock the phone <i>Lock</i>	Menu
Adjust audio volume	
Select the language of your choice <i>Settings > Phone > Language</i>	Menu
Choose the tune <i>Settings > Phone > Ringing</i> Adjust the ring via the following menus: Melody, Silent, Beeps, Volume, etc.	Menu
Adjust the brightness of the set Press the 'I' key <i>> Display > Brightness</i>	
Adjusting screen contrast (8028s/8018) <i>Settings > Phone > Contrast</i>	Menu
Modify the password for your phone set <i>Settings > Phone > Password</i>	Menu
Homepage <i>Settings > Phone > Homepage</i> Select the default page.	Menu